

Hydraulic Motor Model BMMZ



The BMMZ Rotortorc™ gear set, shaft distribution flow, hydraulic motors are a compact, highly efficient, low speed-high torque design which can be used in either parallel or series systems. These low weight advanced construction design motors are manufactured in accordance with the requirements of the ISO 9000-2000 quality system.

Technical Specifications

MODEL		BMMZ 8	BMMZ 12.5	BMMZ 20	BMMZ 32	BMMZ 40	BMMZ 50
Displacement <i>in³/rev (cm³/rev)</i>		0.50 (8.2)	0.79 (12.9)	1.21 (19.9)	1.93 (31.6)	2.43 (39.8)	3.07 (50.3)
Max Speed <i>rpm</i>		1950	1550	1005	630	500	395
Max Torque <i>in•lbf</i>	Cont	97	142	221	354	398	407
	Int.	133	204	310	504	620	779
Max Differential <i>psi</i>	Cont	1450	1450	1450	1450	1305	1015
	Int.	2031	2031	2031	2031	2031	2031
Max Flow <i>gpm</i>		4.23	5.28	5.28	5.25	5.28	5.25
Weight <i>lbs</i>		4.19 lbs	4.41 lbs	4.63 lbs	4.85 lbs	5.08 lbs	5.29 lbs

Continuous = maximum of continuous operation. Intermittent = maximum operating range for 6 seconds per minute

BMMZ Installation Data

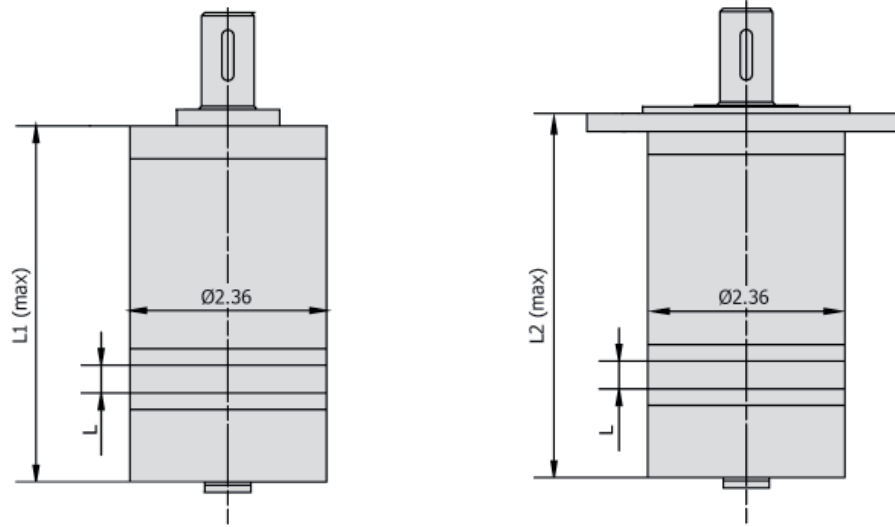

MODEL	L	Rear Ports		Side Ports	
		L1 (Circle Flange)	L2 (2-Bolt Flange)	L1 (Circle Flange)	L2 (2-Bolt Flange)
BMM 8	.138"	4.11"	4.21"	4.17"	4.27"
BMM 12.5	.217"	4.19"	4.29"	4.25"	4.35"
BMM 20	.335"	4.31"	4.41"	4.37"	4.47"
BMM 32	.531"	4.51"	4.61"	4.57"	4.67"
BMM 40	.669"	4.65"	4.74"	4.70"	4.80"
BMM 50	.846"	4.82"	4.92"	4.88"	4.98"

Port Locations

1U - Rear Ports

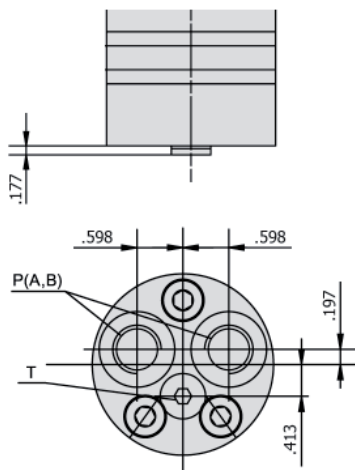

U - Side Ports

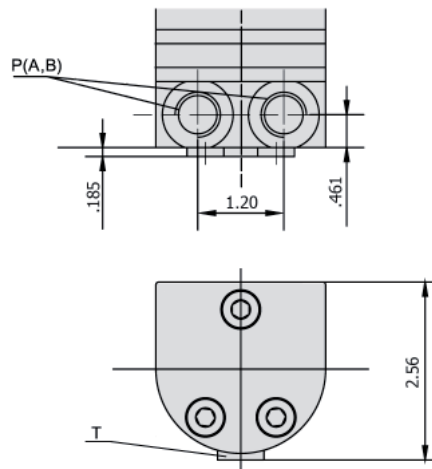

Port Sizes	
P (A,B)	9/16 - 18 SAE
T	3/8 - 24 SAE

Mounting Flanges

U - Circle Flange

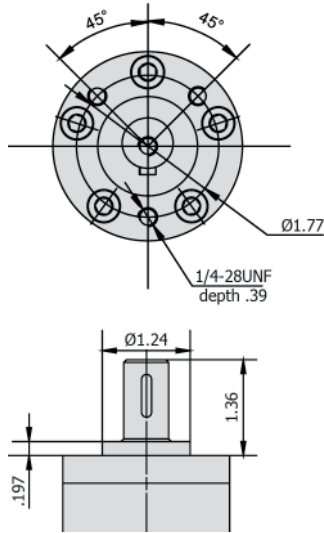

F - 2-Bolt Flange

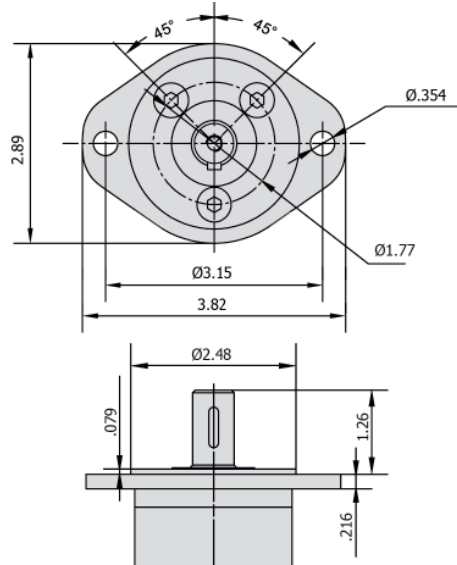

Drive Shaft

B - 5/8" Keyed Shaft

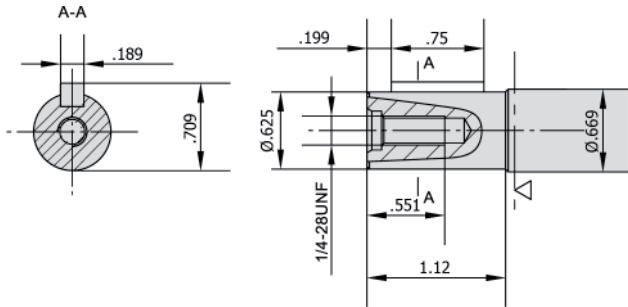

Ordering Example:

Model **BMMZ** - Frame Size **20** - Flange **U** - Drive Shaft **B** - Ports **1U**

Model	Frame Size	Mounting Flange	Drive Shaft	Port Location & Size
BMMZ	8 (0.50) 12.5 (0.76) 20 (1.22) 32 (1.95) 40 (2.44) 50 (3.07)	U = Circle Flange F = 2-Bolt	B = 5/8" Straight Key	U = Side Port: 9/16" - 18 SAE 1U = Back Port: 9/16" - 18 SAE

Seal kits for BMMZ Motors are available for purchase. Order seal kit using item description: "BMMZ Seal Kit".

BMMZ 8								
0.50 in ³ /rev (8.2 cm ³ /rev)								
Pressure (psi →)	510	725	1015	1450 Max Cont.	1750	2030 Max Int.		
F L O W	(gpm ↓)	Torque (in•lbf) Speed Specification						
	0.52	27	44	71	89	106	124	
		228 rpm	218 rpm	206 rpm	156 rpm	111 rpm	58 rpm	
	1.05	27	44	62	97	115	133	
		474 rpm	471 rpm	463 rpm	426 rpm	391 rpm	331 rpm	
	2.10	27	44	62	97	115	133	
		953 rpm	946 rpm	926 rpm	884 rpm	855 rpm	816 rpm	
	3.15	18	44	62	89	115	133	
		1444 rpm	1426 rpm	1402 rpm	1360 rpm	1324 rpm	1288 rpm	
	3.95 Max Cont.		35	62	89	106	124	
		1912 rpm	1900 rpm	1861 rpm	1833 rpm	1780 rpm		
5.25 Max Int.			53	89	97	124		
			2395 rpm	2350 rpm	2328 rpm	2281 rpm		

BMMZ 12.5								
0.76 in ³ /rev (12.9 cm ³ /rev)								
Pressure (psi →)	510	725	1015	1450 Max Cont.	1750	2030 Max Int.		
F L O W	(gpm ↓)	Torque (in•lbf) Speed Specification						
	0.52	53	71	97	142	168		
		140 rpm	136 rpm	119 rpm	68 rpm	35 rpm		
	1.05	53	71	106	150	168	204	
		296 rpm	289 rpm	274 rpm	229 rpm	200 rpm	145 rpm	
	2.10	44	71	106	150	177	212	
		605 rpm	596 rpm	583 rpm	543 rpm	514 rpm	469 rpm	
	3.15	44	71	97	142	177	212	
		912 rpm	905 rpm	895 rpm	859 rpm	834 rpm	784 rpm	
	3.95	44	62	97	142	168	204	
1152 rpm		1144 rpm	1136 rpm	1102 rpm	1078 rpm	1036 rpm		
5.25 Max Cont.	27	62	89	133	168	195		
	1542 rpm	1532 rpm	1521 rpm	1500 rpm	1482 rpm	1437 rpm		
6.57 Max Int.	18	53	80	124	159	195		
	1910 rpm	1891 rpm	1878 rpm	1848 rpm	1828 rpm	1788 rpm		

BMMZ 20								
1.21 in ³ /rev (19.9 cm ³ /rev)								
Pressure (psi →)	246	510	725	1015	1450 Max Cont.	1750	2030 Max Cont.	
F L O W	(gpm ↓)	Torque (in•lbf) Speed Specification						
	0.52	27	80	124	168	230	266	
		99 rpm	96 rpm	89 rpm	74 rpm	42 rpm	21 rpm	
	1.05	35	80	124	168	230	274	319
		197 rpm	191 rpm	182 rpm	178 rpm	134 rpm	112 rpm	74 rpm
	2.10	35	80	115	168	239	274	319
		398 rpm	395 rpm	391 rpm	377 rpm	340 rpm	319 rpm	288 rpm
	3.15	27	71	115	159	230	274	327
		596 rpm	594 rpm	588 rpm	579 rpm	545 rpm	523 rpm	493 rpm
	3.95	27	71	106	150	221	266	319
745 rpm		741 rpm	738 rpm	728 rpm	695 rpm	684 rpm	660 rpm	
5.25 Max Cont.	9	53	97	168	212	257	310	
	998 rpm	995 rpm	991 rpm	985 rpm	962 rpm	916 rpm	885 rpm	
6.57 Max Int.		35	80	124	204	248	292	
		1247 rpm	1245 rpm	1242 rpm	1189 rpm	1180 rpm	1176 rpm	

BMMZ 32		1.90 in ³ /rev (31.6 cm ³ /rev)						
Pressure (psi →)	290	510	725	1015	1450 <i>Max Cont.</i>	1750	2030 <i>Max Int.</i>	
F L O W	(gpm ↓)	Torque (in•lbf) Speed Specification						
	0.52	62	133	186	248	354		
		61 rpm	57 rpm	52 rpm	47 rpm	16 rpm		
	1.05	62	133	186	257	363	425	504
		126 rpm	121 rpm	114 rpm	106 rpm	82 rpm	67 rpm	49 rpm
	2.10	62	133	186	257	363	434	513
		250 rpm	244 rpm	239 rpm	231 rpm	207 rpm	194 rpm	167 rpm
	3.15	53	115	177	248	354	425	513
		378 rpm	374 rpm	369 rpm	362 rpm	338 rpm	322 rpm	297 rpm
	3.95	35	106	159	238	345	416	504
476 rpm		472 rpm	468 rpm	462 rpm	441 rpm	429 rpm	406 rpm	
5.25 <i>Max Cont.</i>	27	89	150	221	327	407	487	
	633 rpm	630 rpm	627 rpm	619 rpm	601 rpm	585 rpm	566 rpm	
6.57 <i>Max Int.</i>	9	71	133	204	310	381	460	
	791 rpm	789 rpm	787 rpm	783 rpm	766 rpm	753 rpm	732 rpm	

BMMZ 40		2.39 in ³ /rev (39.8 cm ³ /rev)					
Pressure (psi →)	510	725	1015	1233 <i>Max Cont.</i>	1450	1750 <i>Max Int.</i>	
F L O W	(gpm ↓)	Torque (in•lbf) Speed Specification					
	0.52	142	239	319	389	451	
		45 rpm	40 rpm	34 rpm	28 rpm	17 rpm	
	1.05	142	239	327	389	460	549
		96 rpm	93 rpm	85 rpm	79 rpm	65 rpm	52 rpm
	2.10	133	230	319	389	460	558
		197 rpm	195 rpm	182 rpm	176 rpm	166 rpm	154 rpm
	3.15	124	221	310	381	451	549
		293 rpm	287 rpm	282 rpm	277 rpm	268 rpm	257 rpm
	3.95	115	212	301	372	443	549
371 rpm		365 rpm	360 rpm	355 rpm	347 rpm	338 rpm	
5.25 <i>Max Cont.</i>	89	186	274	345	425	522	
	497 rpm	492 rpm	487 rpm	480 rpm	472 rpm	463 rpm	
6.57 <i>Max Int.</i>	62	168	257	327	389	496	
	622 rpm	617 rpm	612 rpm	607 rpm	600 rpm	591 rpm	

BMMZ 50		3.02 in ³ /rev (50.3 cm ³ /rev)				
Pressure (psi →)	218	510	725	1015 <i>Max Cont.</i>	1450 <i>Max Int.</i>	
F L O W	(gpm ↓)	Torque (in•lbf) Speed Specification				
	0.52	97	204	319	443	
		37 rpm	33 rpm	27 rpm	22 rpm	
	1.05	97	195	319	443	620
		76 rpm	73 rpm	68 rpm	63 rpm	55 rpm
	2.10	97	186	310	443	628
		157 rpm	154 rpm	149 rpm	145 rpm	137 rpm
	3.15	97	177	292	434	628
		237 rpm	234 rpm	231 rpm	226 rpm	218 rpm
	3.95	89	159	283	415	611
296 rpm		295 rpm	294 rpm	288 rpm	282 rpm	
5.25 <i>Max Cont.</i>	71	124	257	389	566	
	395 rpm	395 rpm	393 rpm	390 rpm	381 rpm	
6.57 <i>Max Int.</i>	35	89	221	354	522	
	498 rpm	496 rpm	494 rpm	490 rpm	484 rpm	

BMM Technical Data

Case Drain

In applications without a motor drain line, the pressure exerted on the shaft seal is marginally in excess of the return line pressure. When the drain line is used the pressure exerted on the shaft seal is equal to the return line pressure.

Standard Direction of Shaft Rotation

When facing the shaft end of the motor, the shaft will rotate:

- Clockwise when port A is pressurized
- Counter-clockwise when port B is pressurized

