

## Rear Port PTO Gear Pump Model GP-PTO

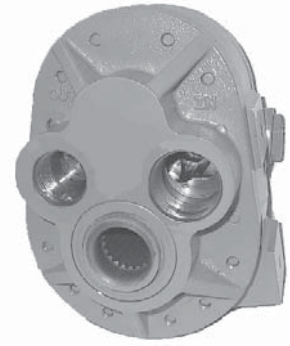

Model GP-PTO is a rear-ported, Power Take Off gear pump constructed with cast iron end plates and an aluminum center section. This pump offers a 9.76 in<sup>3</sup>/rev (160 cm<sup>3</sup>/rev) displacement and higher flows at reduced engine rpm as compared to other PTO pumps. Standard drive is 1 3/8" diameter 21-tooth female spline.

### Recommended working conditions:

- FILTRATION: 25 micron or better
- OIL VISCOSITY: 6 - 200 cSt
- INLET PRESSURE: 12 - 32 psi abs.
- OIL TEMPERATURE: -25° - 80°C (-12° - 175°F)
- AMBIENT TEMPERATURE: -22° - 55°C (-8° - 130°F)

### Technical Specifications

Model	Displacement		Pressure	Speed		Weight
	in <sup>3</sup> /rev	cm <sup>3</sup> /rev	psi	Rated	Max	Lbs
GP-PTO-A-9-21-R	9.76	160	2500	1000	1100	40

Flow Rate (gpm) = Displacement (in<sup>3</sup>/rev) X Speed (rpm) / 231  
 Volumetric efficiency % ≥93

### Installation Data

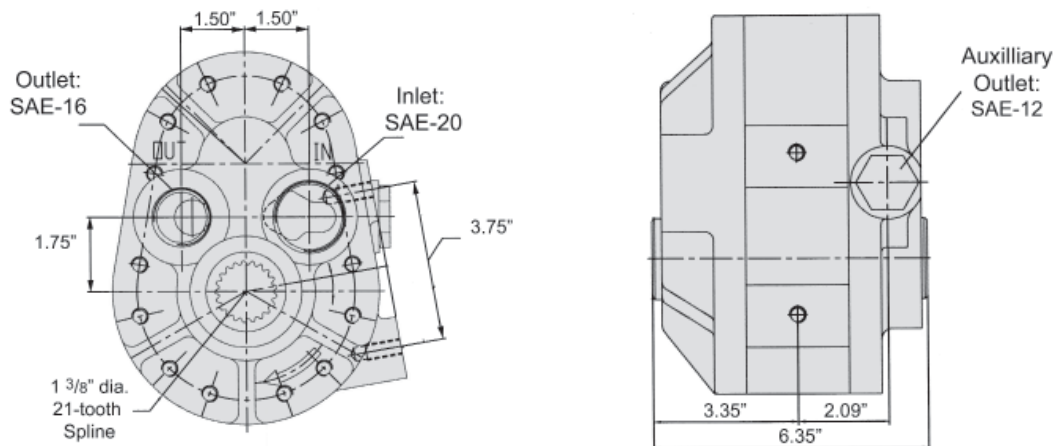

**Ordering Example:** Category **GP** - Series **PTO** - Center **A** - Displacement **9** - Drive **21** - Ports **R**

Category	Series	Center Section	Displacement	Drive	Ports
Gear Pump	PTO = Power Take Off Gear Pump	A = Aluminum	9	21 = 21-tooth Spline	R = Rear Ports

Seal kits for PTO pumps are available. See page 130 for details.