



FLUID COMPONENTS, INC.

# CDS Series Dry Gauges

1 1/2" , 2" and 2 1/2" • Stem & Center Back Mounts

## Features

- Steel Case
- Phosphor Bronze Bourdon Tube
- Bronze Connection
- Polycarbonate Lens
- Built-in Snubber
- Range: Vacuum to 6,000 psi
- Dual Scale: psi & bar
- Accuracy: ± 1.6% FSD
- Temperature Range: -40° to 180° F
- Certificate of Accuracy Available (see page 15 for details)



## Installation Data

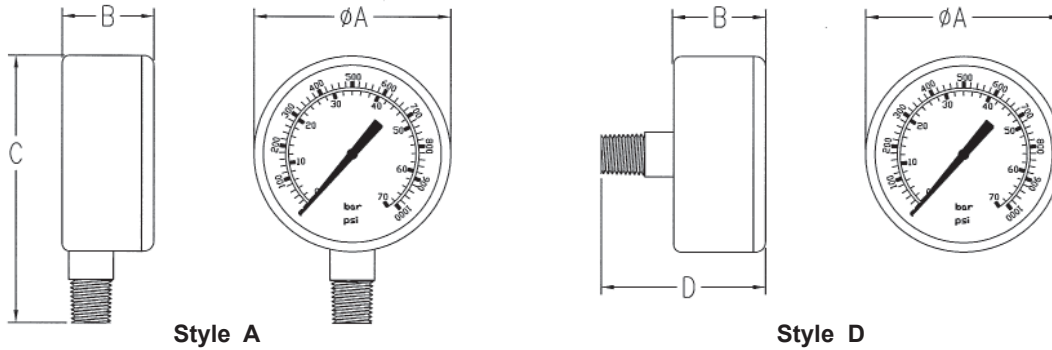

Size	A	B	C	D	Port	Weight	
						Style A	Style D
1 1/2"	1.62"	.90"	2.26"	1.50"	1/8" NPT	.10 lbs	.15 lbs
2"	2.00"	1.08"	2.81"	1.80"	1/4" NPT*	.20 lbs	.20 lbs
2 1/2"	2.45"	1.05"	3.22"	1.75"	1/4" NPT*	.25 lbs	.25 lbs

\* 1/8" NPT available w/ min. order. Add -8N to end of model #.

**Ordering Example:** CDS - 1 P - 210 D

Model	Size	Type	Pressure Range	Style
CDS = Dry Gauge	*4 = 1 1/2" dia. 5 = 2" dia. 1 = 2 1/2" dia.	C = Compound V = Vacuum P = Pressure	002 = 30" Hg - 30 psi** 000 = 30" Hg - 0 psi 001 = 15 psi 002 = 30 psi 004 = 60 psi 007 = 100 psi 010 = 160 psi 015 = 200 psi 020 = 300 psi 040 = 600 psi	A = Stem D = Center Back
			070 = 1000 psi 100 = 1500 psi 140 = 2000 psi 210 = 3000 psi 280 = 4000 psi 350 = 5000 psi 420 = 6000 psi	

Some size/range combinations may only be available by special order.

\* 1 1/2" dia. is limited to 5000 psi

\*\*Additional compound ranges may be available by special order.

Logo and custom gauge faces available with minimum 100 piece order. Call for details.

## CDS Series Dry Gauges 2" and 2 1/2" • Panel Clamp & Flange Mounts

### Features

- Steel Case, Rolled Bezel
- Phosphor Bronze Bourdon Tube
- Bronze Connection
- Polycarbonate Lens
- Built-in Snubber
- Range: Vacuum to 6,000 psi
- Dual Scale: psi & bar
- Accuracy:  $\pm 1.6\%$  FSD
- Temperature Range:  $-40^{\circ}$  to  $180^{\circ}$  F
- Certificate of Accuracy Available (see page 15 for details)



### Installation Data

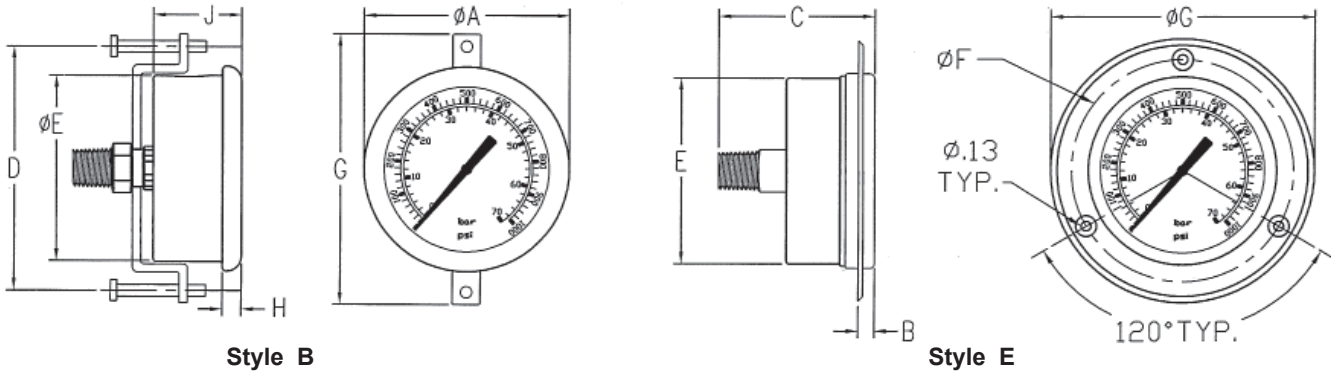

Size	A	B	C	D	E	F	G	H	J	Port	Weight	
											Style B	Style E
2"	2.25"	.20"	1.75"	2.28"	2.05"	2.45"	2.80"	.21"	1.15"	1/4" NPT*	.30	.25
2 1/2"	2.68"	.20"	1.75"	3.14"	2.40"	2.85"	3.29"	.25"	1.17"	1/4" NPT*	.40	.30

\* 1/8" NPT available w/ min. order. Add -8N to end of model #.

**Ordering Example:** Model **CDS** - Size **5** Type **P** - Range **210** Style **E**

Model	Size	Type	Pressure Range	Style	
CDS = Dry Gauge	5 = 2" dia. 1 = 2 1/2" dia.	C = Compound V = Vacuum  P = Pressure	002 = 30" Hg - 30 psi** 000 = 30" Hg - 0 psi  001 = 15 psi 002 = 30 psi 004 = 60 psi 007 = 100 psi 010 = 160 psi 015 = 200 psi 020 = 300 psi 040 = 600 psi	070 = 1000 psi 100 = 1500 psi 140 = 2000 psi 210 = 3000 psi 280 = 4000 psi 350 = 5000 psi 420 = 6000 psi	B = Panel Clamp E = Panel Flange

Some size/range combinations may only be available by special order.

\*\*Additional compound ranges may be available by special order.

Logo and custom gauge faces available with minimum 100 piece order. Call for details.