



FLUID COMPONENTS, INC.

CF Series Gauges

1 1/2", 2" and 2 1/2" • Glycerine-Filled

Features

- 304 Stainless Steel Case & Bezel
- Phosphor Bronze Bourdon Tube
- Bronze Connection
- Polycarbonate Lens
- Built-in Snubber
- Range: Vacuum to 10,000 psi
- Dual Scale: psi & bar
- Accuracy: ± 1.6% FSD
- Temperature Range: -13° to 180°F
- Certificate of Accuracy Available (see page 15 for details)



Installation Data

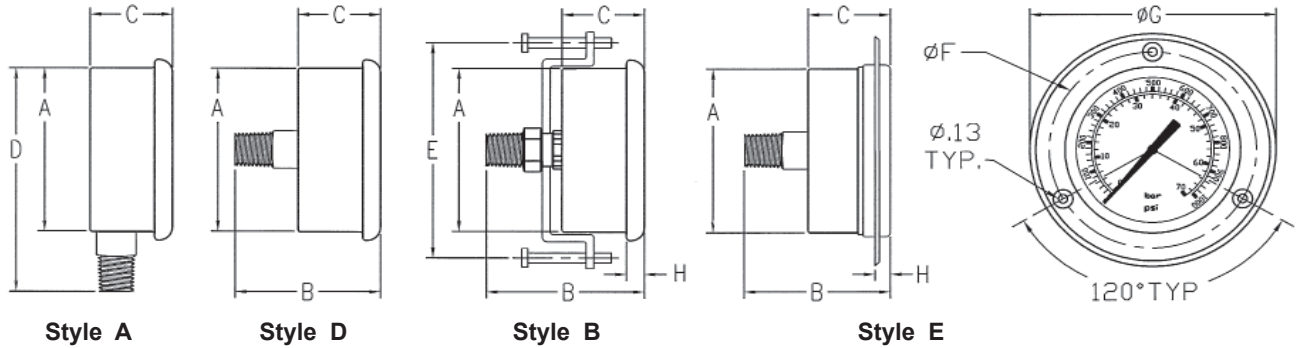

Size	A	B	C	D	E	F	G	H	Port	Weight (in lbs)			
										Style A	Style B	Style D	Style E
1 1/2"	1.58"	1.98"	1.02"	2.47"	2.30"	2.08"	2.45"	.20"	1/8" NPT	.20	.30	.25	.25
2"	1.98"	2.21"	1.19"	3.05"	2.28"	2.40"	2.76"	.24"	1/4" NPT*	.35	.45	.40	.40
2 1/2"	2.40"	2.25"	1.18"	3.45"	3.18"	2.90"	3.42"	.25"	1/4" NPT*	.45	.55	.50	.55

*1/8" NPT available w/ min. order. Add -8N to end of model #.

Ordering Example: CF 1 P - 350 A

Model	Size	Type	Pressure Range	Style
CF =	*4 = 1 1/2" dia.	C = Compound	002 = 30" Hg - 30 psi**	A = Stem
Glycerine-filled	5 = 2" dia.	V = Vacuum	000 = 30" Hg - 0 psi	B = Panel Clamp
Gauge	1 = 2 1/2" dia.	P = Pressure	001 = 15 psi	D = Center Back
			002 = 30 psi	E = Panel Flange
			004 = 60 psi	
			007 = 100 psi	
			010 = 160 psi	
			015 = 200 psi	
			020 = 300 psi	
			040 = 600 psi	
			070 = 1000 psi	
			100 = 1500 psi	
			140 = 2000 psi	
			210 = 3000 psi	
			280 = 4000 psi	
			350 = 5000 psi	
			420 = 6000 psi	
			700 = 10,000 psi	
			800 = 15,000 psi	

Some size/range combinations may only be available by special order.

*Note: 1 1/2" dia. is limited to 6000 psi

**Additional compound ranges may be available by special order.

Logo and custom gauge faces available with minimum 50 piece order. Call for details.

CF Series (SAE) Gauges 2 1/2" • Glycerine-Filled • SAE Swivel Mount

Features

- 304 Stainless Steel Case & Bezel
- Phosphor Bronze Bourdon Tube
- SAE 7/16-20 Bronze Connection
- Polycarbonate Lens
- Built-in Snubber
- Range: Vacuum to 10,000 psi
- Dual Scale: psi & bar
- Accuracy: $\pm 1.6\%$ FSD
- Temperature Range: -13° to 180°F
- Certificate of Accuracy Available
(see page 15 for details)



Installation Data

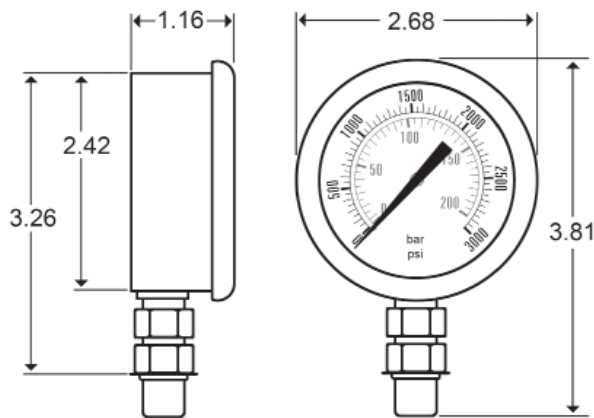

Style A

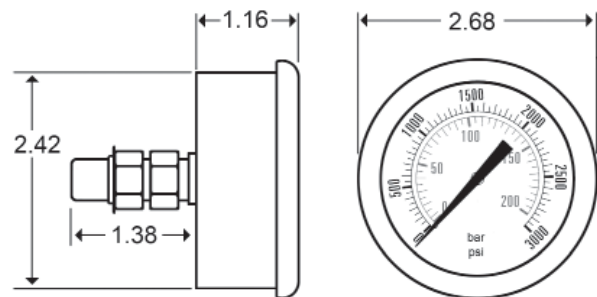

Style D

Ordering Example:

Model **CF** Size **1** Type **P** - Range **210** Style **A** - Connection **SAE**

Model	Size	Type	Pressure Range	Style	Connection	
CF = Glycerine-filled Gauge	1 = 2 1/2"	C = Compound V = Vacuum P = Pressure	002 = 30" Hg - 30 psi** 000 = 30" Hg - 0 psi 001 = 15 psi 002 = 30 psi 004 = 60 psi 007 = 100 psi 010 = 160 psi 015 = 200 psi 020 = 300 psi 040 = 600 psi	070 = 1000 psi 100 = 1500 psi 140 = 2000 psi 210 = 3000 psi 280 = 4000 psi 350 = 5000 psi 420 = 6000 psi 700 = 10,000 psi	A = Stem D = Center Back*	7/16-20UNF (SAE-04)

*Special order - minimum quantities may apply.

**Additional compound ranges may be available by special order.

Logo and custom gauge faces available with minimum 50 piece order. Call for details.