



FLUID COMPONENTS, INC.

PDSS Series Gauges

2 1/2" • All Stainless Steel Gauges

Features

- 304 Stainless Steel Case
- 316 Stainless Steel Connection
- 316 Stainless Steel Bourdon Tube
- Built-in Snubber
- Polycarbonate Lens
- Liquid-Filled & Dry Options
- Ambient Temp: -13° F to 150°F
- Max. Process Temp: 750°F
- Range: Vacuum to 15,000 psi
- Dual Scale: psi & bar
- Accuracy: ± 1.6% FSD
- Certificate of Accuracy Available (see page 15 for details)



Installation Data

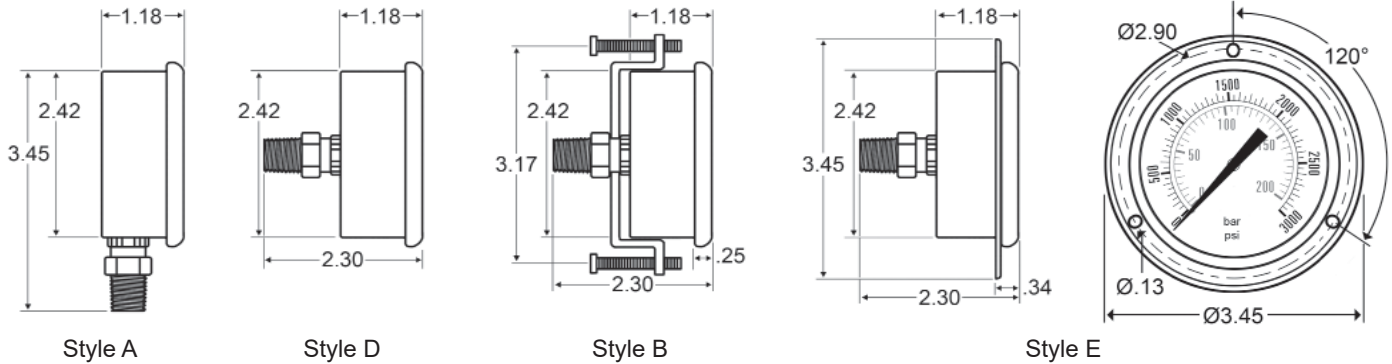

Weight (in lbs)			
Style A	Style B	Style D	Style E
.45	.55	.50	.55

1/4" NPT is the standard connection for all 2 1/2" PDSS gauges.

Ordering Example: **Model** **Size** **Type** **Range** **Style** **Options**

PDSS - 1 P - 040 A - 001

Model	Size	Type	Pressure Range	Style	Options
PDSS = All Stainless Steel Gauges	1 = 2 1/2" dia.	C = Compound V = Vacuum P = Pressure	002 = 30" Hg -30 psi** 000 = 30" Hg - 0 psi 001 = 15 psi 100 = 1500 psi 002 = 30 psi 140 = 2000 psi 004 = 60 psi 210 = 3000 psi 007 = 100 psi 280 = 4000 psi 010 = 160 psi 350 = 5000 psi 015 = 200 psi 420 = 6000 psi 020 = 300 psi 700 = 10,000 psi 040 = 600 psi 800 = 15,000 psi 070 = 1000 psi	A = Stem B = Panel Clamp D = Center Back E = Panel Flange	001 = Glycerine-filled 002 = Dry*

* Special Order
**Additional compound ranges may be available by special order.

PDSS Series Gauges 4" • All Stainless Steel Gauges

Features

- 304 Stainless Steel Case
- 316 Stainless Steel Connection
- 316 Stainless Steel Bourdon Tube
- Built-in Snubber
- Polycarbonate Lens
- Liquid-Filled & Dry Options
- Range: Vacuum to 15,000 psi
- Single Scale: psi
- Ambient Temp: -13° F to 150°F
- Max. Process Temp: 750°F
- Accuracy: ± 1% FSD
- Certificate of Accuracy Available
(see page 15 for details)



Installation Data

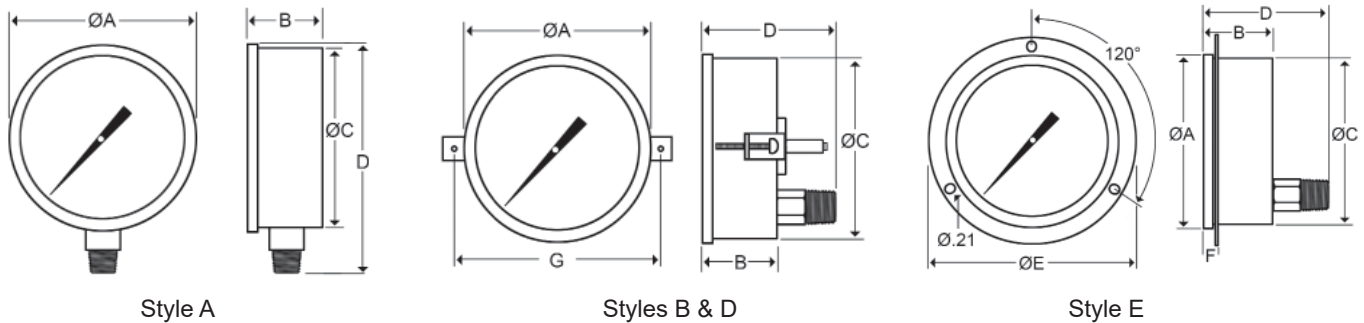

Style	A	B	C	D*	E	F	G	Weight
A - Stem	4.28"	1.84"	3.87"	5.30" (1/4" NPT) 5.36" (1/2" NPT)	-	-	-	1.55
B - Panel Clamp	4.28"	1.87"	3.87"	3.10" (1/4" NPT) 3.20" (1/2" NPT)	-	-	5.00"	1.75
D - Lower Back	4.28"	1.87"	3.87"	3.10" (1/4" NPT) 3.20" (1/2" NPT)	-	-	-	1.65
E - Panel Flange	4.28"	1.87"	3.87"	3.10" (1/4" NPT) 3.20" (1/2" NPT)	5.13"	.27"	-	1.70

*1/4" NPT is standard connection for 600 psi and below; 1/2" NPT is standard for 1000 psi and above

Ordering Example:

Model	Size	Type	Range	Style	Options
PDSS	2	P	070	D	001

Model	Size	Type	Pressure Range	Style	Options
PDSS = All Stainless Steel Gauges	2 = 4" dia.	C = Compound V = Vacuum P = Pressure	002 = 30" Hg -30 psi** 000 = 30" Hg - 0 psi 001 = 15 psi 002 = 30 psi 004 = 60 psi 007 = 100 psi 010 = 160 psi 015 = 200 psi 020 = 300 psi 040 = 600 psi 070 = 1000 psi	A = Stem B = Panel Clamp D = Lower Back E = Panel Flange	001 = Glycerine-filled 002* = Dry

* Special Order

**Additional compound ranges may be available by special order.