

Dynamic Fluid Components offers an extensive range of Low Speed High Torque (LSHT) **ROTORTORC™** and **ROLORTORC™** Hydraulic Motors.

Dynamic motors are manufactured in accordance with ISO 9000-2000 quality standards and have been accepted world wide as a competitively priced, high-quality product. These motors are interchangeable with many leading domestic and European manufacturers. Performance-driven, these products are available from stock throughout the North American market from our extensive distributor network.

USER GUIDE

For optimal utilization of these motors the following is recommended.

1. Normal oil operating temperature should be 70 to 150°F (20 to 60°C).
2. Maximum operating temperature should not exceed 190°F (90°C).
3. Filtration level per ISO Cleanliness Code level 18/3.
4. Minimum oil viscosity should be 100 SUS.
5. Motors should be operated at less than 30% of rated performance for the first hour of operation.
6. Simultaneous maximum torque and maximum speed is NOT recommended.

TECHNICAL DATA

Dynamic motors are offered with either a **ROTORTORC™** or **ROLORTORC™** gear set. The Rotortorc™ gear set employs an interlocking set of teeth making them suitable for long operating periods at moderate pressures or short operating periods at high pressures. Rolortorc™ gear sets have rollers added to the outer ring which act as a roller bearings, reducing friction and wear and increasing mechanical efficiency. This extends the operating life and provides better efficiency at continuous high pressures. The BMMZ & BMPH models use the Rotortorc™ design, while the BMRS, BMSY, BMH, BMT, BMV, BMER-2 and BMK6 use the Rolortorc™ design.

Model	Distributor Type	Displacement		Maximum Operating Pressure (psi)	Speed (rpm)
		(in ³ /rev)	(cm ³ /rev)		
BMMZ	Disc	.5-3.0	8-50	1450	400-1950
BMPH	Axial	2.2-24	36-387	2393	150-1050
BMRS	Axial	3.2-23	52-381	2576	160-755
BMSY	Disc	4.9-29	81-475	3045	155-800
BMH	Axial	12-30	203-489	2580	155-366
BMER-2	Disc	7.2-45	118-745	2973	100-360
BMT	Disc	9.9-49	161-801	2944	154-614
BMV	Disc	20-60	333-990	2900	185-446
BMK6	Disc	12-60	196-982	2900	152-765

Rotortorc™

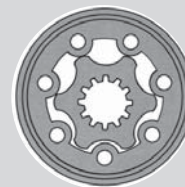

Rolortorc™

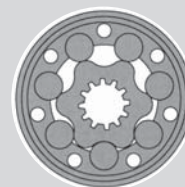

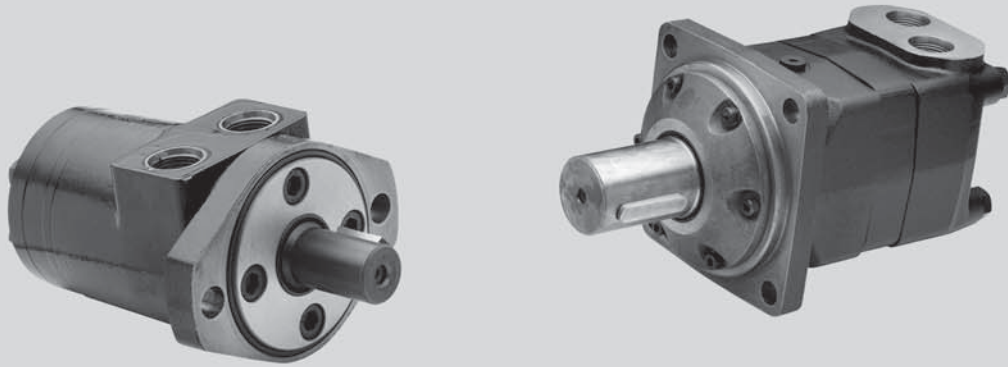

Hydraulic Motor TABLE OF CONTENTS

Low Speed High Torque (Rotortorc™ & Rolortorc™) Motors	Page
BMMZ (Rotortorc™) - Interchangeable w/ Char-Lynn® 129-XXXX, Danfoss OMM & Others	61-66
BMPH (Rotortorc™) - Interchangeable w/ Char-Lynn® 101-XXXX & Others	67-75
BMRS (Rolortorc™) - Interchangeable w/ Char-Lynn® 103-XXXX & Others	76-82
BMSY (Rolortorc™) - Interchangeable w/ Char-Lynn® 104-XXXX, 105-XXXX & Others	83-89
BMH (Rolortorc™) - Interchangeable w/ Danfoss OMH & Others	90-96
BMER-2 (Rolortorc™) - Interchangeable w/ White 500/501 & 530/531 & Others	97-107
BMER-4 (Rolortorc™) - Interchangeable w/ White 520/521 & Others	108
BMT (Rolortorc™) - Interchangeable w/ Char-Lynn® 4000 Series & Others	109-115
BMV (Rolortorc™) - Interchangeable w/ Danfoss OMV & Others	116-122
BMK6 (Rolortorc™) - Interchangeable w/ Char-Lynn® 6000 Series & Others	123-130

* Dynamic motors are interchangeable with many leading domestic and European manufacturers including, Char-Lynn®, Danfoss, White, Parker, RR USA and others. For a list of our most common crossovers, see pages 128-136. Additional crossovers are available by calling: 800-988-1276.

Gear Motors

GM-F10 ("AA" Mount - Gear Motor)	131
GM-F20 ("A" Mount - Gear Motor)	132

Hydraulic Motor Model BMMZ



The BMMZ Rotortorc™ gear set, shaft distribution flow, hydraulic motors are a compact, highly efficient, low speed-high torque design which can be used in either parallel or series systems. These low weight advanced construction design motors are manufactured in accordance with the requirements of the ISO 9000-2000 quality system.

Technical Specifications

MODEL		BMMZ 8	BMMZ 12.5	BMMZ 20	BMMZ 32	BMMZ 40	BMMZ 50
Displacement <i>in³/rev (cm³/rev)</i>		0.50 (8.2)	0.76 (12.9)	1.21 (19.9)	1.93 (31.6)	2.43 (39.8)	3.07 (50.3)
Max Speed <i>rpm</i>	Cont	1950	1550	1000	630	500	400
	Int.	2450	1940	1250	800	630	500
Max Torque <i>in•lbf</i>	Cont	97	141	221	354	398	407
	Int.	132	203	310	504	620	779
Max Differential <i>psi</i>	Cont	1450	1450	1450	1450	1233	1015
	Int.	2030	2030	2030	2030	1740	1450
Max Flow <i>gpm</i>	Cont	3.96	5.28	5.28	5.28	5.28	5.28
	Int.	5.28	6.60	6.60	6.60	6.60	6.60
Weight		4.30 lbs	4.50 lbs	4.72 lbs	4.95 lbs	5.00 lbs	5.10 lbs

Continuous = maximum of continuous operation. Intermittent = maximum operating range for 6 seconds per minute

	Max Inlet Pressure
Cont.	2538 psi
Int.	3263 psi

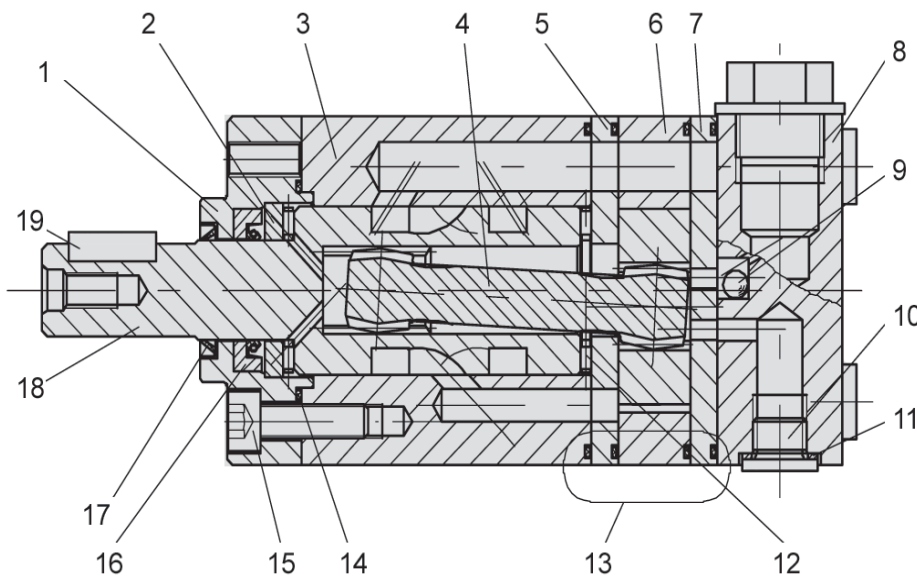
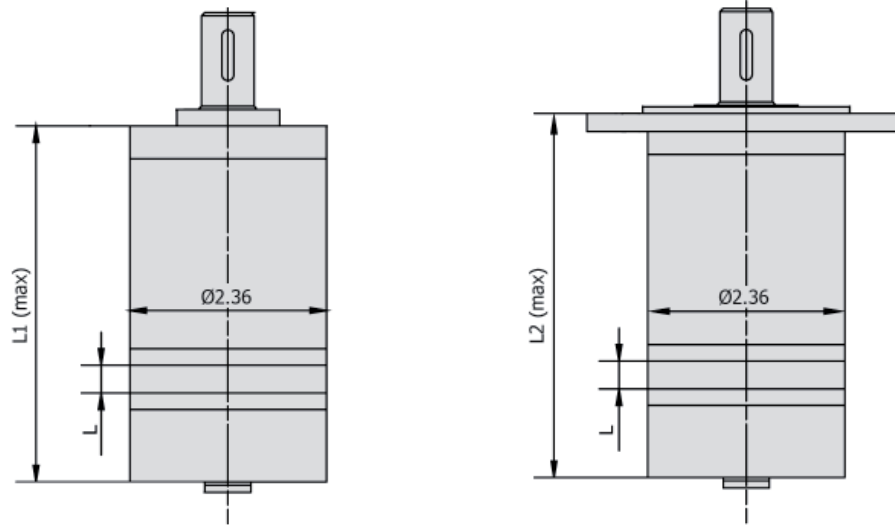

Diagram Key

- 1 Front Cover
- 2 Thrust Washer
- 3 Housing
- 4 Drive Link
- 5 Front Plate
- 6 Rotortorc Gear Set
- 7 End Plate
- 8 End Cover
- 9 Ball
- 10 Drain Plug
- 11 Washer
- 12 Axial Needle Bearing
- 13 "O" Ring
- 14 "O" Ring
- 15 Screw
- 16 Shaft Seal
- 17 Dust Deal
- 18 Shaft
- 19 Key

BMMZ Installation Data



MODEL	L	Rear Ports		Side Ports	
		L1 (Circle Flange)	L2 (2-Bolt Flange)	L1 (Circle Flange)	L2 (2-Bolt Flange)
BMM 8	.138"	4.11"	4.21"	4.17"	4.27"
BMM 12.5	.217"	4.19"	4.29"	4.25"	4.35"
BMM 20	.335"	4.31"	4.41"	4.37"	4.47"
BMM 32	.531"	4.51"	4.61"	4.57"	4.67"
BMM 40	.669"	4.65"	4.74"	4.70"	4.80"
BMM 50	.846"	4.82"	4.92"	4.88"	4.98"

Port Locations

1U - Rear Ports

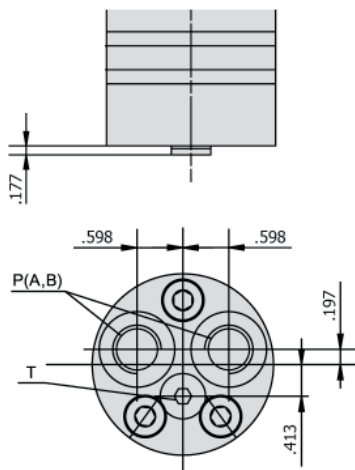

U - Side Ports

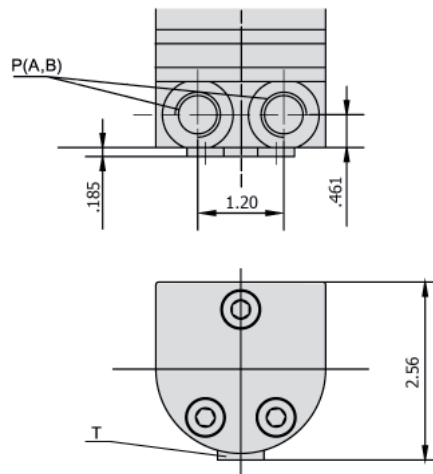

	Port Sizes
P (A,B)	9/16-18 UNF
T	3/8-24 UNF

Mounting Flanges

U - Circle Flange

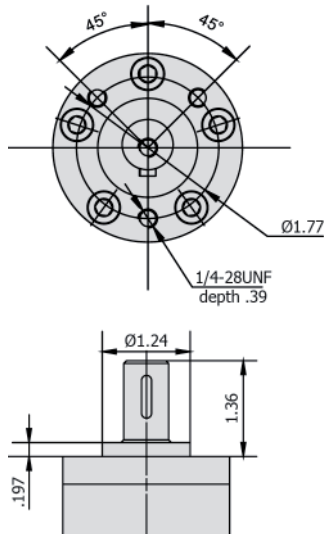

F - 2-Bolt Flange

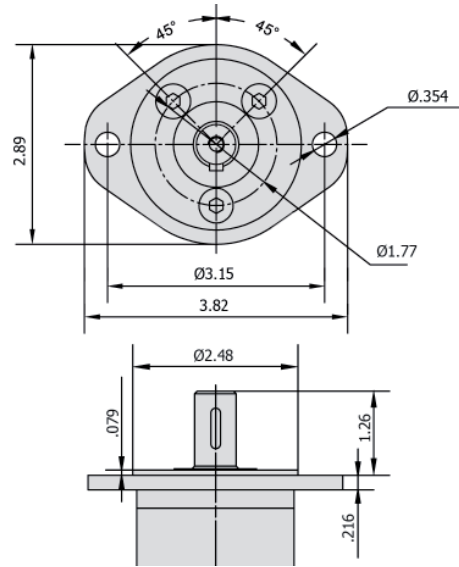

Drive Shaft

B - 5/8" Keyed Shaft

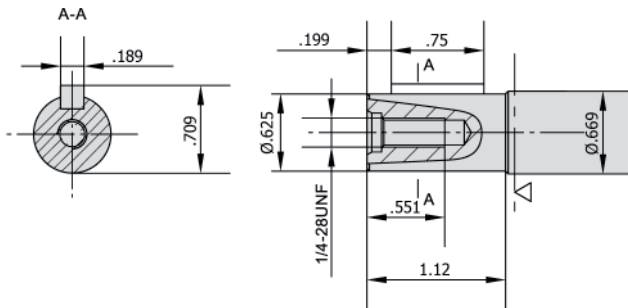

Ordering Example:

Model **BMMZ** - Frame Size **20** - Flange **U** - Drive Shaft **B** - Ports **1U**

Model	Frame Size	Mounting Flange	Drive Shaft	Port Location & Size
BMMZ	8 (0.50) 12.5 (0.76) 20 (1.22) 32 (1.95) 40 (2.44) 50 (3.07)	U = Circle Flange F = 2-Bolt	B = 5/8" Straight Key	U = Side Port (9/16-18 UNF) 1U = Back Port (9/16-18 UNF)

Seal kits for BMMZ Motors are available for purchase. Order seal kit using item description: "BMMZ Seal Kit".

BMMZ 8								
0.50 in ³ /rev (8.2 cm ³ /rev)								
<i>Max Cont.</i>								
<i>Max Int.</i>								
Pressure (psi →)	510	725	1015	1450	1750	2030		
F L O W	(gpm ↓)	Torque (in·lbf) Speed Specification						
	0.52	27	44	71	89	106	124	
		228 rpm	218 rpm	206 rpm	156 rpm	111 rpm	58 rpm	
	1.05	27	44	62	97	115	133	
		474 rpm	471 rpm	463 rpm	426 rpm	391 rpm	331 rpm	
	2.10	27	44	62	97	115	133	
		953 rpm	946 rpm	926 rpm	884 rpm	855 rpm	816 rpm	
	3.15	18	44	62	89	115	133	
		1444 rpm	1426 rpm	1402 rpm	1360 rpm	1324 rpm	1288 rpm	
	3.95 <i>Max Cont.</i>		35	62	89	106	124	
		1912 rpm	1900 rpm	1861 rpm	1833 rpm	1780 rpm		
5.25 <i>Max Int.</i>			53	89	97	124		
			2395 rpm	2350 rpm	2328 rpm	2281 rpm		

BMMZ 12.5								
0.76 in ³ /rev (12.9 cm ³ /rev)								
<i>Max Cont.</i>								
<i>Max Int.</i>								
Pressure (psi →)	510	725	1015	1450	1750	2030		
F L O W	(gpm ↓)	Torque (in·lbf) Speed Specification						
	0.52	53	71	97	142	168		
		140 rpm	136 rpm	119 rpm	68 rpm	35 rpm		
	1.05	53	71	106	150	168	204	
		296 rpm	289 rpm	274 rpm	229 rpm	200 rpm	145 rpm	
	2.10	44	71	106	150	177	212	
		605 rpm	596 rpm	583 rpm	543 rpm	514 rpm	469 rpm	
	3.15	44	71	97	142	177	212	
		912 rpm	905 rpm	895 rpm	859 rpm	834 rpm	784 rpm	
	3.95	44	62	97	142	168	204	
1152 rpm		1144 rpm	1136 rpm	1102 rpm	1078 rpm	1036 rpm		
5.25 <i>Max Cont.</i>	27	62	89	133	168	195		
	1542 rpm	1532 rpm	1521 rpm	1500 rpm	1482 rpm	1437 rpm		
6.57 <i>Max Int.</i>	18	53	80	124	159	195		
	1910 rpm	1891 rpm	1878 rpm	1848 rpm	1828 rpm	1788 rpm		

BMMZ 20								
1.21 in ³ /rev (19.9 cm ³ /rev)								
<i>Max Cont.</i>								
<i>Max Int.</i>								
Pressure (psi →)	246	510	725	1015	1450	1750	2030	
F L O W	(gpm ↓)	Torque (in·lbf) Speed Specification						
	0.52	27	80	124	168	230	266	
		99 rpm	96 rpm	89 rpm	74 rpm	42 rpm	21 rpm	
	1.05	35	80	124	168	230	274	319
		197 rpm	191 rpm	182 rpm	178 rpm	134 rpm	112 rpm	74 rpm
	2.10	35	80	115	168	239	274	319
		398 rpm	395 rpm	391 rpm	377 rpm	340 rpm	319 rpm	288 rpm
	3.15	27	71	115	159	230	274	327
		596 rpm	594 rpm	588 rpm	579 rpm	545 rpm	523 rpm	493 rpm
	3.95	27	71	106	150	221	266	319
745 rpm		741 rpm	738 rpm	728 rpm	695 rpm	684 rpm	660 rpm	
5.25 <i>Max Cont.</i>	9	53	97	168	212	257	310	
	998 rpm	995 rpm	991 rpm	985 rpm	962 rpm	916 rpm	885 rpm	
6.57 <i>Max Int.</i>		35	80	124	204	248	292	
		1247 rpm	1245 rpm	1242 rpm	1189 rpm	1180 rpm	1176 rpm	

BMMZ 32		1.90 in³/rev (31.6 cm³/rev)				<i>Max Cont.</i>	<i>Max Int.</i>	
Pressure (psi →)		290	510	725	1015	1450	1750	2030
FLOW	(gpm ↓)	Torque (in·lbf) Speed Specification						
	0.52	62	133	186	248	354		
		61 rpm	57 rpm	52 rpm	47 rpm	16 rpm		
	1.05	62	133	186	257	363	425	504
		126 rpm	121 rpm	114 rpm	106 rpm	82 rpm	67 rpm	49 rpm
	2.10	62	133	186	257	363	434	513
		250 rpm	244 rpm	239 rpm	231 rpm	207 rpm	194 rpm	167 rpm
	3.15	53	115	177	248	354	425	513
		378 rpm	374 rpm	369 rpm	362 rpm	338 rpm	322 rpm	297 rpm
	3.95	35	106	159	238	345	416	504
476 rpm		472 rpm	468 rpm	462 rpm	441 rpm	429 rpm	406 rpm	
5.25 <i>Max Cont.</i>	27	89	150	221	327	407	487	
	633 rpm	630 rpm	627 rpm	619 rpm	601 rpm	585 rpm	566 rpm	
6.57 <i>Max Int.</i>	9	71	133	204	310	381	460	
	791 rpm	789 rpm	787 rpm	783 rpm	766 rpm	753 rpm	732 rpm	

BMMZ 40		2.39 in³/rev (39.8 cm³/rev)				<i>Max Cont.</i>	<i>Max Int.</i>
Pressure (psi →)		510	725	1015	1233	1450	1750
FLOW	(gpm ↓)	Torque (in·lbf) Speed Specification					
	0.52	142	239	319	389	451	
		45 rpm	40 rpm	34 rpm	28 rpm	17 rpm	
	1.05	142	239	327	389	460	549
		96 rpm	93 rpm	85 rpm	79 rpm	65 rpm	52 rpm
	2.10	133	230	319	389	460	558
		197 rpm	195 rpm	182 rpm	176 rpm	166 rpm	154 rpm
	3.15	124	221	310	381	451	549
		293 rpm	287 rpm	282 rpm	277 rpm	268 rpm	257 rpm
	3.95	115	212	301	372	443	549
371 rpm		365 rpm	360 rpm	355 rpm	347 rpm	338 rpm	
5.25 <i>Max Cont.</i>	89	186	274	345	425	522	
	497 rpm	492 rpm	487 rpm	480 rpm	472 rpm	463 rpm	
6.57 <i>Max Int.</i>	62	168	257	327	389	496	
	622 rpm	617 rpm	612 rpm	607 rpm	600 rpm	591 rpm	

BMMZ 50		3.02 in³/rev (50.3 cm³/rev)				<i>Max Cont.</i>	<i>Max Int.</i>
Pressure (psi →)		218	510	725	1015	1450	
FLOW	(gpm ↓)	Torque (in·lbf) Speed Specification					
	0.52	97	204	319	443		
		37 rpm	33 rpm	27 rpm	22 rpm		
	1.05	97	195	319	443	620	
		76 rpm	73 rpm	68 rpm	63 rpm	55 rpm	
	2.10	97	186	310	443	628	
		157 rpm	154 rpm	149 rpm	145 rpm	137 rpm	
	3.15	97	177	292	434	628	
		237 rpm	234 rpm	231 rpm	226 rpm	218 rpm	
	3.95	89	159	283	415	611	
296 rpm		295 rpm	294 rpm	288 rpm	282 rpm		
5.25 <i>Max Cont.</i>	71	124	257	389	566		
	395 rpm	395 rpm	393 rpm	390 rpm	381 rpm		
6.57 <i>Max Int.</i>	35	89	221	354	522		
	498 rpm	496 rpm	494 rpm	490 rpm	484 rpm		

BMMZ Technical Data

Shaft Seal Rated Pressure

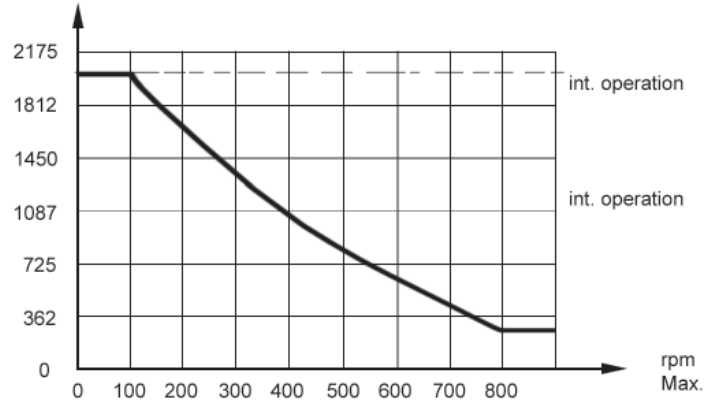
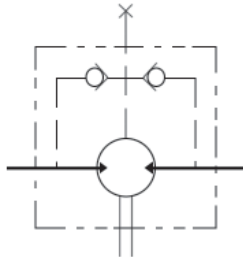

Case Drain

In applications without a motor drain line, the pressure exerted on the shaft seal is marginally in excess of the return line pressure. When the drain line is used the pressure exerted on the shaft seal is equal to the return line pressure.

Shaft Rotation Direction

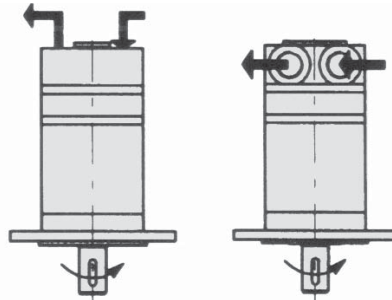

Radial Forces

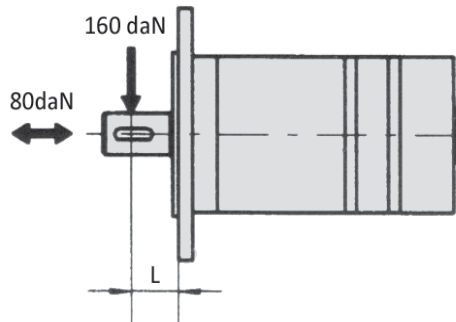

$$F_r = \frac{13040}{61.5 + L}$$

F_r = Radial Force (daN)
 L = Distance (mm)
 n = Speed (rpm)

Rhomb Flange $L=15$ mm
 Square Flange $L=20$ mm

Hydraulic Motor Model BMPH



The BMPH Rotortorc™ gear set, shaft distribution flow, hydraulic motor is a compact, highly efficient, low speed-high torque design which can be used in either parallel or series systems. These low weight advanced construction design motors are manufactured in accordance with the requirements of the ISO 9000-2000 quality system.

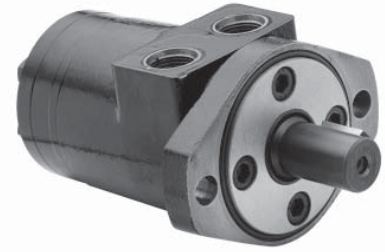

Technical Specifications

MODEL		BMPH 36	BMPH 50	BMPH 80	BMPH 100	BMPH 125	BMPH 160	BMPH 200	BMPH 250	BMPH 315	BMPH 400
Displacement <i>in³/rev (cm³/rev)</i>		2.20 (36.0)	3.15 (51.7)	4.74 (77.7)	5.87 (96.2)	7.20 (120)	9.51 (157)	11.59 (195)	14.66 (240)	19.03 (315)	23.61 (390)
Max Speed <i>rpm</i>	Cont.	1500	1150	770	615	490	383	310	250	192	155
	Int.	1650	1450	960	770	615	475	385	310	240	190
Max Torque <i>in•lbf</i>	Cont.	487	885	1292	1611	2089	2673	3186	4071	4204	4337
	Int.	673	1133	1646	2009	2567	3275	3894	5045	4912	5133
Max Differential <i>psi</i>	Cont.	1813	2031	2031	2031	2031	2031	2031	2031	1813	1450
	Int.	2393	2538	2538	2538	2538	2538	2538	2538	2031	1813
Max Flow <i>gpm</i>	Cont.	14.53	15.85	15.85	15.85	15.85	15.85	15.85	15.85	15.85	15.85
	Int.	15.85	19.82	19.82	19.82	19.82	19.82	19.82	19.82	19.82	19.82
Weight		13.90 lbs	13.85 lbs	14.25 lbs	14.45 lbs	14.70 lbs	15.15 lbs	15.60 lbs	16.15 lbs	16.95 lbs	17.75 lbs

Continuous (Cont.) = maximum of continuous operation. Intermittent (Int.) = maximum operating range for 6 seconds per minute

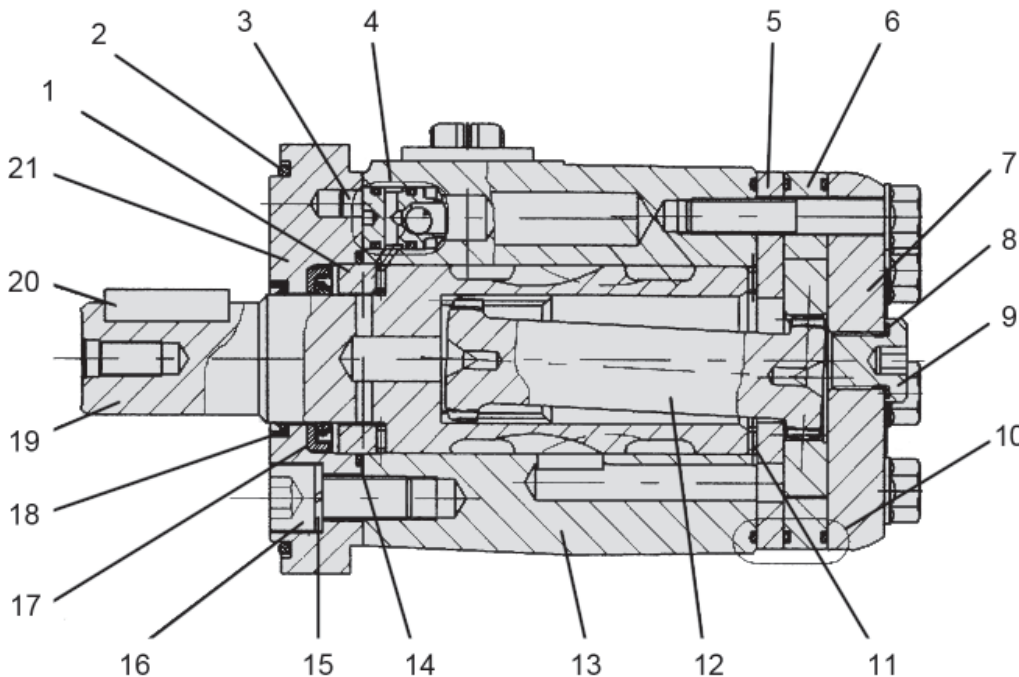
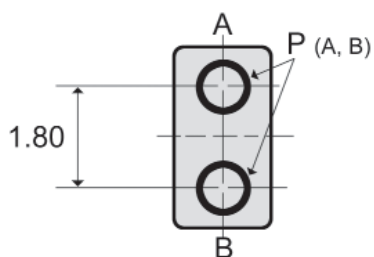
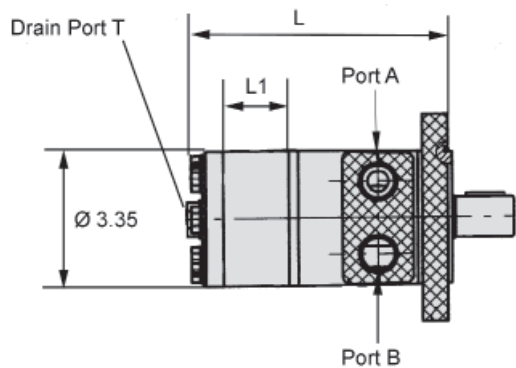

Diagram Key

- 1 Thrust Washer
- 2 "O" Ring
- 3 Pin
- 4 Check Valve
- 5 Wear Plate
- 6 Rotortorc™ Gear Set
- 7 End Cover
- 8 Seal
- 9 Case Drain Plug
- 10 "O" Ring
- 11 Thrust Needle Bearing
- 12 Drive Shaft
- 13 Housing
- 14 "O" Ring
- 15 Lock Washer
- 16 Bolt
- 17 Shaft Seal
- 18 Dust Seal
- 19 Output Shaft
- 20 Key
- 21 Front Cover

BMPH Installation Data



Manifold Mount

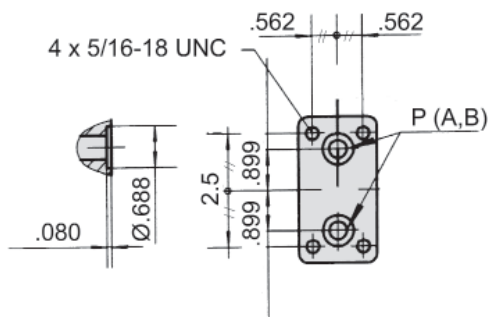

MODEL	L	L1
BMPH 36	5.55"	.28"
BMPH 50	5.55"	.28"
BMPH 80	5.69"	.41"
BMPH 100	5.79"	.51"
BMPH 125	5.91"	.63"
BMPH 160	6.10"	.83"
BMPH 200	6.30"	1.02"
BMPH 250	6.54"	1.26"
BMPH 315	6.93"	1.65"
BMPH 400	7.32"	2.05"

H2 - SAE "A" 2-Bolt

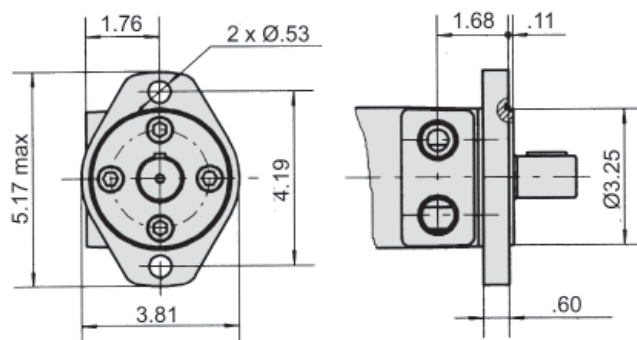

H4 - 4-Bolt

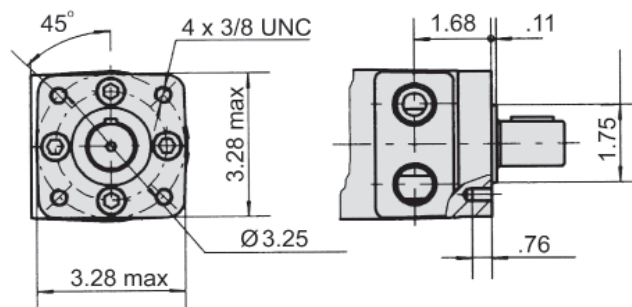

H6 - Magneto

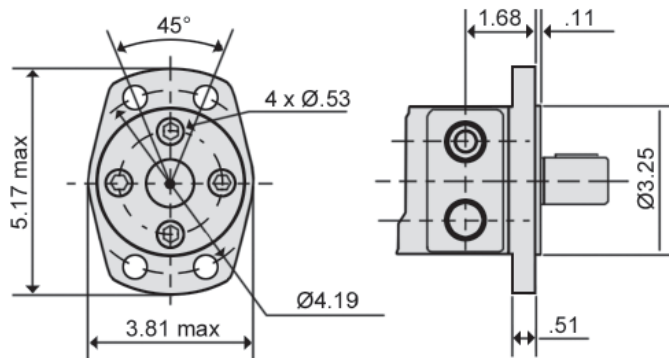

Ports	SAE Sizes	NPT Sizes
P (A, B)	7/8-14 UNF	1/2-14 NPTF
T	7/16-20 UNF	7/16-20 UNF

BMPH Drive Shaft Data

K - 1" Woodruff Key

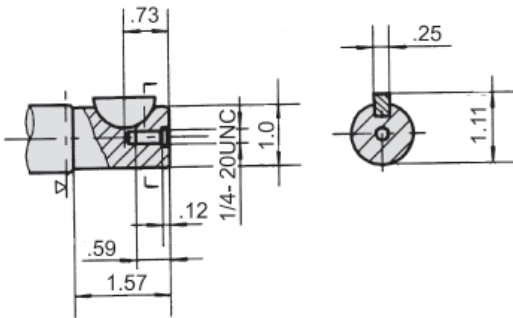

H - 1" Parallel .40 Dia. Cross Hole

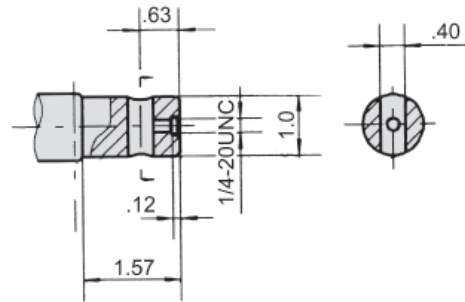

S - SAE 6B Spline

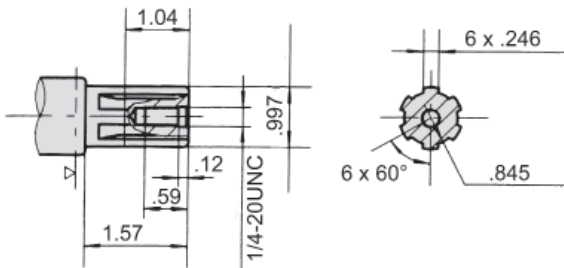

H1 - 1" Parallel .31 Dia. Cross Hole

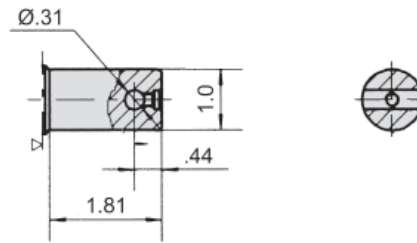

Ordering Example: Model **BMPH** - Frame Size **100** - Flange **H2** - Drive Shaft **K** - Ports **P** - Options

Model	Frame Size	Mounting Flange**	Drive Shaft**	Port Size	Options
BMPH	36 (2.20) 50 (3.15) 80 (4.74) 100 (5.87) 125 (7.34) 160 (9.59) 200 (11.87) 250 (14.66) 315 (19.19) 400 (23.77)	H2 = SAE "A" 2-Bolt H4 = SAE "A" 4-Bolt H6 = Magneto	K = 1" Woodruff Key S = SAE 6B Spline H = 1" Parallel .40 dia. Cross Hole H1 = 1" Parallel .31 dia. Cross Hole	P = 1/2 NPTF S = 7/8 -14 SAE F = Manifold	F* = Free Running N* = 1800 lb. Radial Load Bearings R* = Reverse Rotation

*Special Order

**Additional flange and drive shaft options available please consult factory.

Seal kits for BMPH Motors are available for purchase. Order seal kit using item description: "BMPH Seal Kit".

BMPH Flow Data

BMPH 36		2.20 in ³ /rev (36 cm ³ /rev)						Max Cont.	Max Int.
Pressure (psi →)		435	870	1015	1160	1450	1595	1813	2393
F L O W	(gpm ↓)	Torque (in•lbf) Speed Specification							
	2.11	115.00	221	257	301	381	425		
		214 rpm	205 rpm	200 rpm	194 rpm	187 rpm	179 rpm		
	3.96	115	221	257	301	381	425	496	664
		406 rpm	398 rpm	391 rpm	383 rpm	374 rpm	366 rpm	353 rpm	324 rpm
	5.28	115	212	257	301	381	425	496	673
		541 rpm	534 rpm	528 rpm	521 rpm	513 rpm	500 rpm	486 rpm	458 rpm
	7.93	106	212	257	301	381	425	496	673
		814 rpm	804 rpm	792 rpm	778 rpm	763 rpm	749 rpm	726 rpm	701 rpm
	9.25	106	204	248	301	381	425	496	673
		952 rpm	944 rpm	930 rpm	913 rpm	897 rpm	879 rpm	858 rpm	833 rpm
	10.57	106	204	248	283	363	416	487	664
		1090 rpm	1078 rpm	1064 rpm	1048 rpm	1024 rpm	998 rpm	977 rpm	943 rpm
	11.89	97	195	230	283	363	407	478	655
1232 rpm		1218 rpm	1196 rpm	1175 rpm	1149 rpm	1118 rpm	1080 rpm	1044 rpm	
14.53 Max Cont.	53	133	195	248	327	389	460	628	
	1505 rpm	1494 rpm	1480 rpm	1466 rpm	1438 rpm	1406 rpm	1367 rpm	1309 rpm	
15.85 Max Int.	27	97	159	177	266	336	434	593	
	1650 rpm	1640 rpm	1626 rpm	1603 rpm	1571 rpm	1536 rpm	1502 rpm	1446 rpm	

BMPH 50		3.15 in ³ /rev (51.7 cm ³ /rev)					Max Cont.	Max Int.	
Pressure (psi →)		435	870	1160	1450	1813	2031	2321	2538
F L O W	(gpm ↓)	Torque (in•lbf) Speed Specification							
	2.11	177	363	496	611	788	841		
		151 rpm	134 rpm	115 rpm	90 rpm	56 rpm	42 rpm		
	3.96	168	354	496	628	805	885	991	1062
		286 rpm	274 rpm	261 rpm	243 rpm	204 rpm	182 rpm	139 rpm	102 rpm
	5.28	159	345	487	628	814	894	1036	1133
		382 rpm	373 rpm	361 rpm	348 rpm	318 rpm	309 rpm	287 rpm	251 rpm
	7.93	150	336	487	628	805	867	1027	1097
		573 rpm	568 rpm	558 rpm	535 rpm	503 rpm	488 rpm	462 rpm	440 rpm
	9.25	150	336	478	611	788	867	1036	1097
		670 rpm	661 rpm	652 rpm	640 rpm	606 rpm	589 rpm	562 rpm	548 rpm
	11.89	124	319	469	593	779	867	1009	1089
		863 rpm	858 rpm	849 rpm	837 rpm	807 rpm	788 rpm	764 rpm	746 rpm
	14.53	106	292	443	575	752	850	982	1071
1055 rpm		1042 rpm	1028 rpm	1010 rpm	979 rpm	963 rpm	947 rpm	920 rpm	
15.85 Max Cont.	89	283	416	566	735	832	956	1053	
	1150 rpm	1143 rpm	1126 rpm	1111 rpm	1079 rpm	1065 rpm	1043 rpm	1015 rpm	
19.82 Max Int.	53	221	372	496	673	770	894	991	
		1430 rpm	1416 rpm	1395 rpm	1367 rpm	1351 rpm	1335 rpm	1312 rpm	

BMPH 80		4.74 in ³ /rev (77.7 cm ³ /rev)						<i>Max Cont.</i>		<i>Max Int.</i>
Pressure (psi →)		435	870	1160	1450	1813	2031	2321	2538	
F L O W	(gpm ↓)	Torque (in·lbf) Speed Specification								
	2.11	283	549	752	920	1142	1275			
		97 rpm	87 rpm	74 rpm	55 rpm	33 rpm	22 rpm			
	3.96	283	558	743	947	1115	1275	1460		
		186 rpm	181 rpm	170 rpm	154 rpm	132 rpm	118 rpm	86 rpm		
	5.28	274	558	743	947	1168	1292	1487	1637	
		251 rpm	243 rpm	236 rpm	225 rpm	207 rpm	196 rpm	178 rpm	155 rpm	
	7.93	274	549	735	938	1159	1292	1487	1646	
		381 rpm	379 rpm	368 rpm	355 rpm	332 rpm	316 rpm	285 rpm	263 rpm	
	9.25	266	522	717	903	1151	1275	1478	1637	
		443 rpm	435 rpm	426 rpm	415 rpm	397 rpm	383 rpm	361 rpm	342 rpm	
	11.89	221	513	699	885	1115	1257	1460	1611	
		570 rpm	564 rpm	554 rpm	543 rpm	526 rpm	509 rpm	483 rpm	458 rpm	
	14.53	204	504	690	859	1097	1239	1425	1584	
		696 rpm	685 rpm	672 rpm	656 rpm	643 rpm	630 rpm	602 rpm	579 rpm	
	15.85 <i>Max Cont.</i>	177	469	664	832	1062	1213	1416	1567	
		761 rpm	753 rpm	744 rpm	736 rpm	720 rpm	706 rpm	681 rpm	660 rpm	
	19.82 <i>Max Int.</i>	124	389	593	770	991	1336	1496	1496	
948 rpm		940 rpm	931 rpm	920 rpm	906 rpm	890 rpm	871 rpm	854 rpm		

BMPH 100		5.87 in ³ /rev (96.2 cm ³ /rev)						<i>Max Cont.</i>		<i>Max Int.</i>
Pressure (psi →)		435	870	1160	1450	1813	2031	2321	2538	
F L O W	(gpm ↓)	Torque (in·lbf) Speed Specification								
	2.11	354	682	929	1151	1425	1593			
		81 rpm	75 rpm	69 rpm	57 rpm	36 rpm	24 rpm			
	3.96	345	682	938	1151	1416	1593	1841		
		152 rpm	149 rpm	145 rpm	140 rpm	122 rpm	103 rpm	81 rpm		
	5.28	319	655	920	1133	1425	1584	1814	2009	
		204 rpm	200 rpm	195 rpm	190 rpm	177 rpm	166 rpm	148 rpm	133 rpm	
	7.93	292	637	912	1106	1416	1567	1797	1991	
		308 rpm	304 rpm	298 rpm	290 rpm	280 rpm	268 rpm	255 rpm	231 rpm	
	9.25	266	620	867	1080	1407	1558	1788	1983	
		360 rpm	352 rpm	343 rpm	331 rpm	320 rpm	306 rpm	294 rpm	275 rpm	
	11.89	257	593	841	1044	1372	1540	1770	1947	
		462 rpm	458 rpm	451 rpm	443 rpm	433 rpm	419 rpm	402 rpm	383 rpm	
	14.53	221	566	823	1027	1345	1505	1752	1921	
		566 rpm	558 rpm	549 rpm	540 rpm	529 rpm	515 rpm	498 rpm	478 rpm	
	15.85 <i>Max Cont.</i>	195	531	805	1009	1319	1478	1717	1885	
		618 rpm	611 rpm	601 rpm	589 rpm	580 rpm	570 rpm	558 rpm	540 rpm	
	19.82 <i>Max Int.</i>	133	478	735	938	1248	1416	1646	1814	
771 rpm		763 rpm	755 rpm	744 rpm	735 rpm	724 rpm	708 rpm	693 rpm		

BMPH 125		7.34 in ³ /rev (120.2 cm ³ /rev)							<i>Max Cont.</i>		<i>Max Int.</i>	
Pressure (psi →)		435	870	1160	1450	1813	2031	2321	2538			
W O R K	(gpm ↓)	Torque (in·lbf) Speed Specification										
	2.11	451	867	1213	1487	1841	2089					
		63 rpm	60 rpm	55 rpm	47 rpm	28 rpm	15 rpm					
	3.96	451	894	1221	1487	1850	2089	2363				
		121 rpm	116 rpm	110 rpm	102 rpm	89 rpm	73 rpm	48 rpm				
	5.28	425	867	1195	1478	1867	2098	2381	2567			
		162 rpm	158 rpm	153 rpm	148 rpm	137 rpm	128 rpm	109 rpm	94 rpm			
	7.93	407	850	1168	1452	1850	2053	2337	2540			
		243 rpm	239 rpm	234 rpm	227 rpm	216 rpm	202 rpm	189 rpm	176 rpm			
	9.25	372	814	1151	1416	1823	2027	2301	2514			
		284 rpm	279 rpm	274 rpm	269 rpm	259 rpm	247 rpm	231 rpm	222 rpm			
	11.89	327	788	1106	1390	1779	1983	2310	2487			
		370 rpm	362 rpm	355 rpm	348 rpm	340 rpm	327 rpm	310 rpm	296 rpm			
	14.53	292	743	1080	1345	1735	1929	2230	2434			
452 rpm		446 rpm	438 rpm	431 rpm	420 rpm	412 rpm	402 rpm	384 rpm				
15.85 <i>Max Cont.</i>	257	690	1036	1292	1690	1903	2195	2407				
	490 rpm	482 rpm	475 rpm	468 rpm	459 rpm	448 rpm	439 rpm	427 rpm				
19.82 <i>Max Int.</i>	159	584	947	1177	1584	1788	2089	2301				
	615 rpm	606 rpm	598 rpm	586 rpm	575 rpm	563 rpm	549 rpm	528 rpm				

BMPH 160		9.59 in ³ /rev (157.2 cm ³ /rev)							<i>Max Cont.</i>		<i>Max Int.</i>	
Pressure (psi →)		435	870	1160	1450	1813	2031	2321	2538			
W O R K	(gpm ↓)	Torque (in·lbf) Speed Specification										
	2.11	549	1062	1505	1876	2328	2567					
		49 rpm	48 rpm	46 rpm	42 rpm	26 rpm	14 rpm					
	3.96	531	1080	1522	1903	2337	2602	3009				
		93 rpm	91 rpm	88 rpm	85 rpm	76 rpm	68 rpm	48 rpm				
	5.28	504	1062	1505	1894	2319	2567	3009	3284			
		125 rpm	123 rpm	120 rpm	117 rpm	110 rpm	106 rpm	92 rpm	81 rpm			
	7.93	469	1018	1452	1823	2292	2549	2965	3257			
		187 rpm	184 rpm	181 rpm	178 rpm	175 rpm	168 rpm	155 rpm	139 rpm			
	9.25	434	974	1416	1788	2257	2514	2903	3204			
		220 rpm	216 rpm	213 rpm	209 rpm	205 rpm	202 rpm	192 rpm	176 rpm			
	11.89	389	903	1363	1735	2195	2460	2841	3169			
		283 rpm	280 rpm	276 rpm	272 rpm	267 rpm	260 rpm	250 rpm	238 rpm			
	14.53	354	876	1310	1690	2151	2407	2797	3107			
345 rpm		342 rpm	340 rpm	336 rpm	331 rpm	328 rpm	320 rpm	303 rpm				
15.85 <i>Max Cont.</i>	292	832	1275	1664	2089	2363	2726	3053				
	377 rpm	374 rpm	371 rpm	367 rpm	363 rpm	359 rpm	353 rpm	342 rpm				
19.82 <i>Max Int.</i>	168	708	1097	1505	1912	2230	2620	2876				
	473 rpm	469 rpm	465 rpm	459 rpm	453 rpm	447 rpm	440 rpm	424 rpm				

BMPH 200		11.87 in ³ /rev (194.5 cm ³ /rev)						<i>Max Cont.</i>		<i>Max Int.</i>
Pressure (psi →)		435	870	1160	1450	1813	2031	2321	2538	
FLOW	(gpm ↓)	Torque (in·lbf) Speed Specification								
	2.11	699	1452	1832	2213	2832	3186			
		40 rpm	39 rpm	38 rpm	35 rpm	28 rpm	22 rpm			
	3.96	690	1434	1814	2213	2850	3195	3629		
		76 rpm	75 rpm	74 rpm	71 rpm	66 rpm	61 rpm	51 rpm		
	5.28	673	1398	1797	2186	2832	3169	3567	3735	
		100 rpm	98 rpm	97 rpm	95 rpm	92 rpm	89 rpm	73 rpm	57 rpm	
	7.93	620	1354	1770	2168	2788	3098	3523	3691	
		151 rpm	149 rpm	147 rpm	145 rpm	142 rpm	139 rpm	131 rpm	120 rpm	
	9.25	584	1319	1717	2053	2629	3036	3416	3673	
		177 rpm	175 rpm	173 rpm	171 rpm	168 rpm	166 rpm	160 rpm	149 rpm	
	11.89	558	1292	1682	2036	2602	3009	3390	3629	
		228 rpm	226 rpm	224 rpm	221 rpm	218 rpm	215 rpm	210 rpm	198 rpm	
	14.53	478	1239	1602	1983	2531	2956	3284	3540	
280 rpm		278 rpm	276 rpm	274 rpm	271 rpm	269 rpm	263 rpm	250 rpm		
15.85 <i>Max Cont.</i>	336	1124	1452	1876	2390	2876	3151	3496		
	304 rpm	302 rpm	300 rpm	297 rpm	294 rpm	291 rpm	286 rpm	272 rpm		
19.82 <i>Max Int.</i>	195	850	1283	1699	2080	2593	2841	3248		
	382 rpm	378 rpm	374 rpm	371 rpm	368 rpm	364 rpm	360 rpm	350 rpm		

BMPH 250		14.66 in ³ /rev (240.3 cm ³ /rev)						<i>Max Cont.</i>		<i>Max Int.</i>
Pressure (psi →)		435	870	1160	1450	1813	2031	2321	2538	
FLOW	(gpm ↓)	Torque (in·lbf) Speed Specification								
	2.11	850	1682	2372	2885	3567				
		30 rpm	28 rpm	24 rpm	21 rpm	11 rpm				
	3.96	867	1717	2390	2894	3585	3983	4514		
		60 rpm	58 rpm	54 rpm	50 rpm	40 rpm	30 rpm	12 rpm		
	5.28	814	1664	2363	2876	3585	4036	4549	5001	
		82 rpm	80 rpm	77 rpm	76 rpm	69 rpm	64 rpm	52 rpm	38 rpm	
	7.93	752	1593	2292	2832	3540	3965	4540	4965	
		123 rpm	120 rpm	118 rpm	114 rpm	106 rpm	98 rpm	87 rpm	76 rpm	
	9.25	682	1558	2230	2753	3443	3859	4461	4930	
		143 rpm	141 rpm	139 rpm	135 rpm	128 rpm	122 rpm	112 rpm	101 rpm	
	11.89	620	1487	2151	2655	3337	3788	4381	4806	
		185 rpm	182 rpm	178 rpm	174 rpm	168 rpm	161 rpm	152 rpm	139 rpm	
	14.53	558	1407	2098	2567	3266	3691	4275	4700	
226 rpm		223 rpm	218 rpm	213 rpm	209 rpm	202 rpm	193 rpm	185 rpm		
15.85 <i>Max Cont.</i>	531	1328	2018	2478	3169	3602	4186	4602		
	248 rpm	246 rpm	243 rpm	239 rpm	233 rpm	226 rpm	215 rpm	207 rpm		
19.82 <i>Max Int.</i>	301	1133	1788	2337	3027	3425	3965	4319		
	309 rpm	306 rpm	302 rpm	297 rpm	292 rpm	286 rpm	278 rpm	264 rpm		

BMPH 315		19.19 in ³ /rev (314.5 cm ³ /rev)					Max Cont.	Max Int.	
Pressure (psi →)	435	725	1015	1305	1450	1813	2031		
F L O W	(gpm ↓)	Torque (in•lbf) Speed Specification							
	2.11	1089	1903	2584	3257	3585			
		25 rpm	23 rpm	21 rpm	17 rpm	11 rpm			
	3.96	1044	1867	2540	3248	3576	4381	5027	
		47 rpm	46 rpm	44 rpm	40 rpm	28 rpm	21 rpm	10 rpm	
	5.28	974	1814	2460	3186	3496	4372	5009	
		62 rpm	61 rpm	60 rpm	57 rpm	46 rpm	40 rpm	36 rpm	
	7.93	894	1735	2399	3089	3434	4337	5001	
		94 rpm	93 rpm	91 rpm	88 rpm	76 rpm	68 rpm	65 rpm	
	9.25	850	1664	2337	3018	3381	4231	4930	
		109 rpm	107 rpm	106 rpm	104 rpm	96 rpm	89 rpm	84 rpm	
	11.89	788	1593	2248	2983	3292	4142	4894	
		141 rpm	140 rpm	138 rpm	135 rpm	127 rpm	120 rpm	115 rpm	
	14.53	673	1469	2115	2876	3204	4045	4850	
173 rpm		172 rpm	170 rpm	167 rpm	160 rpm	152 rpm	143 rpm		
15.85 Max Cont.	575	1363	2009	2726	3080	3921	4682		
	188 rpm	186 rpm	184 rpm	182 rpm	178 rpm	172 rpm	163 rpm		
19.82 Max Int.	354	1062	1779	2469	2859	3700	4399		
	236 rpm	234 rpm	232 rpm	228 rpm	226 rpm	223 rpm	214 rpm		

BMPH 400		23.77 in ³ /rev (389.5 cm ³ /rev)					Max Cont.	Max Int.	
Pressure (psi →)	435	653	798	943	1160	1450	1813		
F L O W	(gpm ↓)	Torque (in•lbf) Speed Specification							
	2.11	1469	2053	2540	3009	3700			
		20 rpm	19 rpm	18 rpm	16 rpm	12 rpm			
	3.96	1460	2018	2452	2983	3691	4390	5417	
		38 rpm	36 rpm	35 rpm	33 rpm	31 rpm	27 rpm	21 rpm	
	5.28	1434	1974	2416	2930	3655	4381	5381	
		50 rpm	49 rpm	49 rpm	48 rpm	45 rpm	41 rpm	35 rpm	
	7.93	1363	1912	2354	2815	3585	4301	5310	
		76 rpm	75 rpm	74 rpm	73 rpm	71 rpm	67 rpm	60 rpm	
	9.25	1292	1859	2266	2761	3496	4248	5204	
		88 rpm	87 rpm	87 rpm	86 rpm	83 rpm	80 rpm	75 rpm	
	11.89	1168	1744	2151	2655	3390	4107	5098	
		114 rpm	113 rpm	112 rpm	110 rpm	108 rpm	106 rpm	99 rpm	
	14.53	1036	1629	2009	2505	3213	3983	4886	
139 rpm		137 rpm	136 rpm	135 rpm	135 rpm	132 rpm	123 rpm		
15.85 Max Cont.	903	1443	1903	2407	3071	3859	4709		
	153 rpm	152 rpm	150 rpm	148 rpm	146 rpm	143 rpm	138 rpm		
19.82 Max Int.	469	1133	1611	2071	2815	3461	4284		
	191 rpm	189 rpm	187 rpm	185 rpm	183 rpm	180 rpm	176 rpm		

BMPH Technical Data

Shaft Seal Rated Pressure

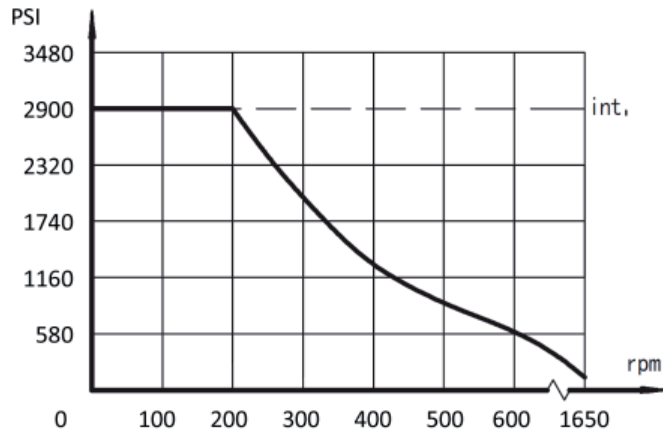
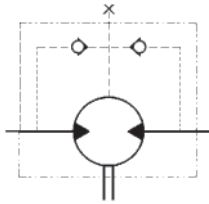

Case Drain

In applications without a motor drain line, the pressure exerted on the shaft seal is marginally in excess of the return line pressure. When the drain line is used, the pressure exerted on the shaft seal is equal to the return line pressure.

Shaft Rotation Direction

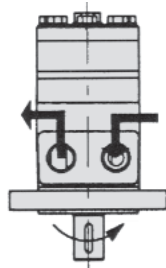

Radial Forces

Status of the shaft's radial force

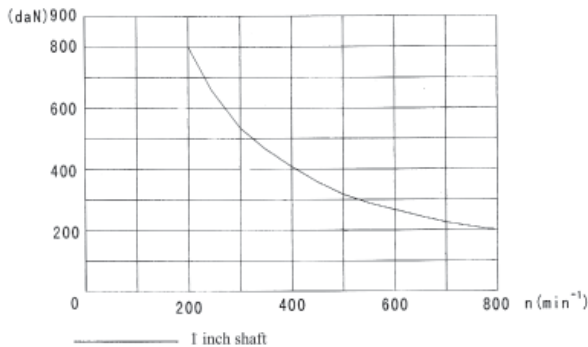

$$F_r = \frac{800}{n} * \frac{25000}{95 + L}$$

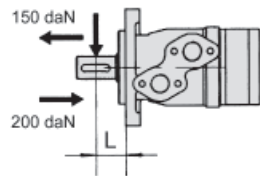

F_r = Radial Force (daN)
 L = Distance (mm)
 n = Speed (rpm)

Rhomb Flange $L=30\text{mm}$
 Square Flange $L=24\text{mm}$



FLUID COMPONENTS, INC.

Hydraulic Motor Model BMRS



The BMRS series advanced **ROLORTORC™** gear set, shaft distribution flow, hydraulic motor is a compact, low noise, high efficient high torque low speed design. The **ROLORTORC™** gear set also affords a reliable smooth start up at low pressure. BMRS motors are available with optional radial needle bearings (by special order) for side load applications.

The low weight advanced construction design is manufactured in accordance with the requirements of ISO 9000-2000 quality system.

Technical Specifications

MODEL		BMRS 50	BMRS 80	BMRS 100	BMRS 125	BMRS 160	BMRS 200	BMRS 250	BMRS 315	BMRS 375
Displacement	<i>in³/rev</i>	3.15	4.97	6.22	7.76	9.59	11.87	15.46	19.36	23.27
	<i>(cm³/rev)</i>	(51.7)	(81.5)	(102)	(127.2)	(157.2)	(194.5)	(253.3)	(317.5)	(381.4)
Max Speed	Cont	960	750	600	475	378	310	240	190	155
	rpm	Int.	1150	940	750	600	475	385	300	240
Max Torque	Cont	885	1726	2124	2655	3186	3186	3451	3451	3230
	<i>in•lbf</i>	Int.	1115	1947	2478	3009	3805	3894	4336	4735
Max Differential	Cont	2031	2321	2321	2321	2321	2321	2321	2031	1450
	<i>psi</i>	Int.	2538	2900	2900	2900	2900	2900	2900	2538
Max Flow	Cont	13.21	15.85	15.85	15.85	15.85	15.85	15.85	15.85	15.85
	<i>gpm</i>	Int.	15.85	19.81	19.81	19.81	19.81	19.81	19.81	19.81
Weight		16.20 lbs	16.80 lbs	17.35 lbs	17.95 lbs	18.65 lbs	19.35 lbs	20.65 lbs	22.10 lbs	23.30 lbs

Continuous = maximum of continuous operation. Intermittent = maximum operating range for 6 seconds per minute

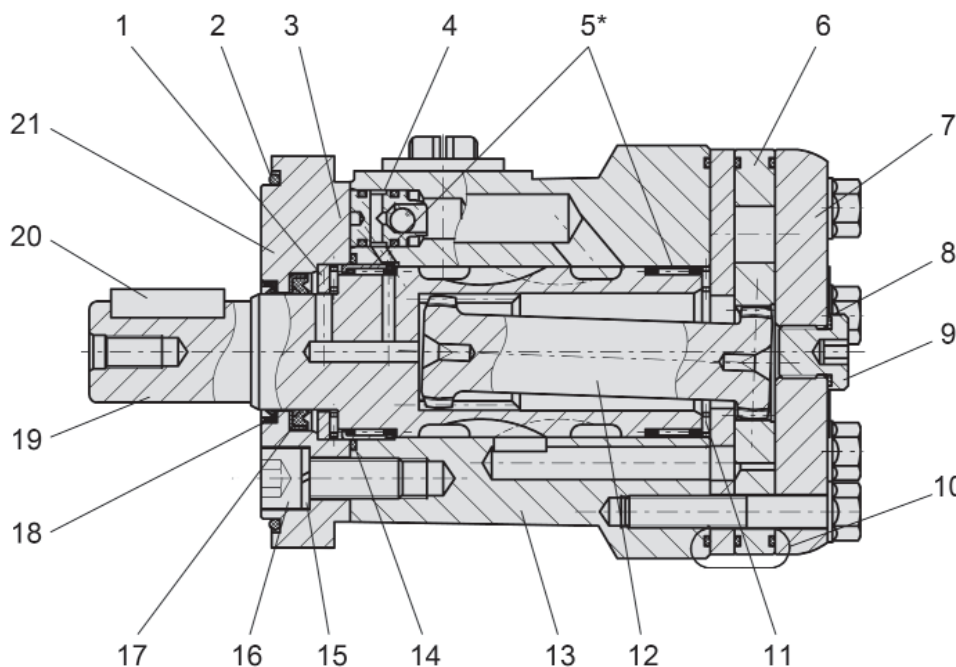
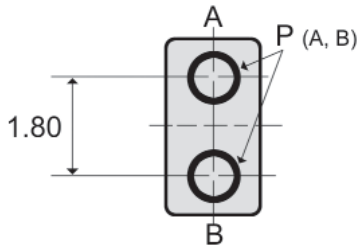
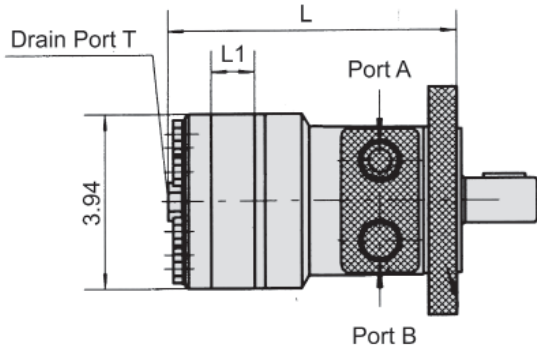

Diagram Key

- 1 Thrust Washer
- 2 "O" Ring
- 3 Pin
- 4 Check Valve
- 5 Radial Needle Bearings
- 6 Rolortorc™ Gear Set
- 7 End Cover
- 8 Seal
- 9 Case Drain Plug
- 10 "O" Ring
- 11 Thrust Needle Bearing (2)
- 12 Drive Shaft
- 13 Housing
- 14 "O" Ring
- 15 Lock Washer
- 16 Bolt
- 17 Shaft Seal
- 18 Dust Seal
- 19 Output Shaft
- 20 Key
- 21 Front Cover

*Shown with optional radial needle bearings for side load applications.

BMRS Installation Data



Manifold Port

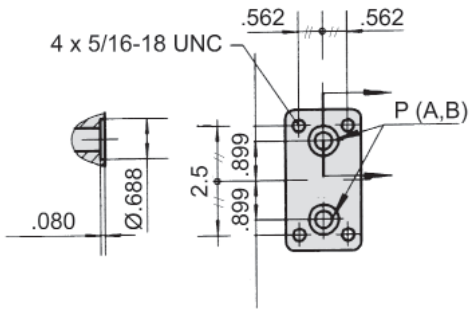

MODEL	L	L1
BMRS 50	5.67"	.39"
BMRS 80	5.90"	.63"
BMRS 100	6.06"	.79"
BMRS 125	6.26"	.98"
BMRS 160	6.51"	1.24"
BMRS 200	6.85"	1.57"
BMRS 250	7.24"	1.97"
BMRS 315	7.72"	2.44"
BMRS 375	8.19"	2.91"

H2 - SAE "A" 2-Bolt

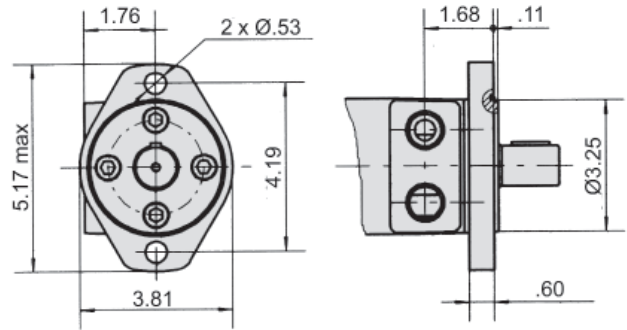

H4 - 4-Bolt

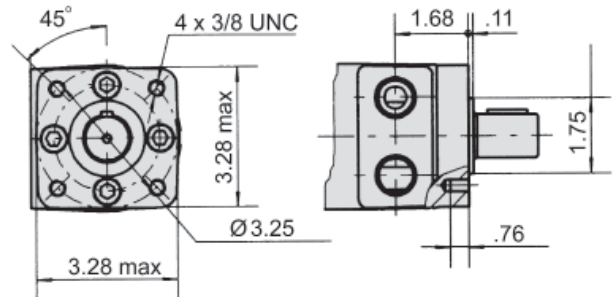

H6 - Magneto

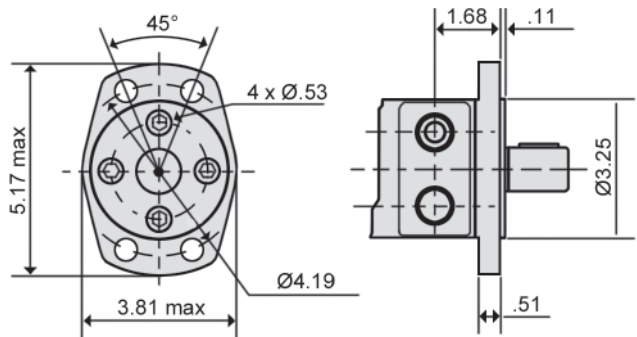

Ports	SAE Sizes	NPT Sizes
P (A, B)	7/8-14 UNF	1/2-14 NPTF
T	7/16-20 UNF	7/16-20 UNF

BMRS Drive Shaft Data

K - 1" Woodruff Key

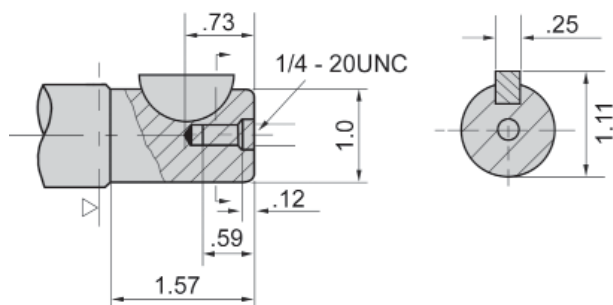

H - 1" Parallel .40 Dia. Cross Hole

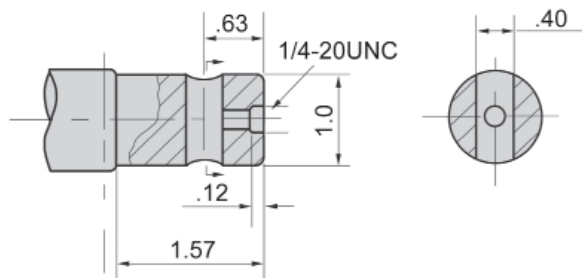

S - SAE 6B Spline

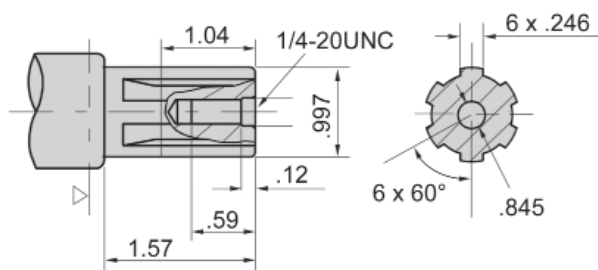

H1 - 1" Parallel .31 Dia. Cross Hole

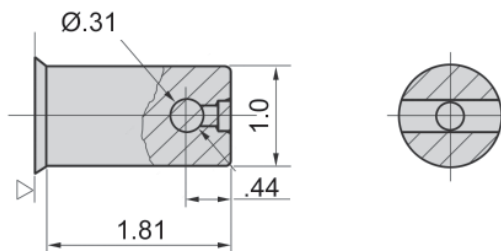

Ordering Example:

Model	Frame Size	Flange	Drive Shaft	Ports	Options
BMRS	250	H4	K	S	

Model	Frame Size	Mounting Flange**	Drive Shaft**	Port Size	Options
BMRS	50 (3.15) 80 (4.97) 100 (6.22) 125 (7.76) 160 (9.59) 200 (11.87) 250 (15.46) 315 (19.38) 375 (23.27)	H2 = SAE "A" 2-Bolt H4 = SAE "A" 4-Bolt H6 = Magneto	K = 1" Woodruff Key S = SAE 6B Spline H = 1" Parallel .40 dia. Cross Hole H1 = 1" Parallel .31 dia. Cross Hole	P = 1/2 NPTF S = 7/8-14 UNF F = Manifold	F* = Free Running N* = 1800 lb. Radial Load Bearings

*Special Order

**Additional flange and drive shaft options available please consult factory.

Seal kits for BMRS Motors are available for purchase. Order seal kit using item description: "BMRS Seal Kit".

BMRS 50		3.15 in ³ /rev (51.7 cm ³ /rev)					Max Cont.		Max Int.	
Pressure (psi →)		725	1015	1305	1450	1740	2031	2321	2538	
FLOW	(gpm ↓)	Torque (in·lbf) Speed Specification								
	1.32	310	398	540	593	682	779			
		93 rpm	84 rpm	76 rpm	73 rpm	69 rpm	46 rpm			
	2.64	319	407	549	611	708	841	956	1062	
		186 rpm	178 rpm	166 rpm	162 rpm	153 rpm	136 rpm	118 rpm	97 rpm	
	3.96	310	434	558	646	779	885	965	1089	
		283 rpm	277 rpm	269 rpm	261 rpm	250 rpm	230 rpm	211 rpm	185 rpm	
	5.28	305	416	540	611	735	850	965	1115	
		377 rpm	375 rpm	365 rpm	361 rpm	346 rpm	330 rpm	302 rpm	270 rpm	
	7.93	292	389	531	593	708	841	956	1115	
		576 rpm	569 rpm	561 rpm	554 rpm	542 rpm	531 rpm	500 rpm	465 rpm	
	10.57	266	363	513	584	699	814	938	1080	
		760 rpm	758 rpm	753 rpm	750 rpm	738 rpm	724 rpm	700 rpm	670 rpm	
11.89	261	354	504	575	690	797	929	1071		
	856 rpm	853 rpm	849 rpm	845 rpm	835 rpm	815 rpm	796 rpm	770 rpm		
13.21 Max Cont.	230	327	469	531	646	752	876	1009		
	950 rpm	940 rpm	925 rpm	906 rpm	880 rpm	852 rpm	832 rpm	801 rpm		
15.85 Max Int.	177	292	425	496	611	717	841	965		
	1138 rpm	1124 rpm	1100 rpm	1075 rpm	1056 rpm	1028 rpm	1006 rpm	970 rpm		

BMRS 80		4.97 in ³ /rev (81.5 cm ³ /rev)					Max Cont.		Max Int.	
Pressure (psi →)		725	1015	1305	1450	1740	2031	2321	2538	2901
FLOW	(gpm ↓)	Torque (in·lbf) Speed Specification								
	1.32	443	566	779	956	1177				
		59 rpm	56 rpm	50 rpm	44 rpm	38 rpm				
	2.64	478	682	876	956	1142	1328	1531		
		118 rpm	113 rpm	106 rpm	97 rpm	86 rpm	79 rpm	56 rpm		
	5.28	504	690	903	982	1186	1372	1567	1735	1991
		238 rpm	234 rpm	227 rpm	216 rpm	203 rpm	190 rpm	178 rpm	154 rpm	135 rpm
	7.93	478	664	885	956	1159	1345	1558	1726	1974
		360 rpm	352 rpm	340 rpm	332 rpm	316 rpm	302 rpm	290 rpm	274 rpm	250 rpm
	10.57	425	646	850	929	1124	1310	1522	1682	1947
		480 rpm	470 rpm	458 rpm	445 rpm	430 rpm	418 rpm	403 rpm	388 rpm	359 rpm
	13.21	372	620	823	903	1097	1301	1505	1664	1929
		604 rpm	595 rpm	582 rpm	570 rpm	556 rpm	540 rpm	521 rpm	504 rpm	487 rpm
15.85 Max Cont.	327	584	788	867	1071	1275	1469	1629	1885	
	726 rpm	715 rpm	704 rpm	692 rpm	678 rpm	663 rpm	647 rpm	622 rpm	594 rpm	
18.49	283	531	735	841	1027	1239	1416	1567	1841	
	845 rpm	834 rpm	820 rpm	802 rpm	789 rpm	767 rpm	754 rpm	730 rpm	705 rpm	
19.82 Max Int.	186	443	690	797	982	1195	1363	1513	1770	
	910 rpm	895 rpm	881 rpm	867 rpm	852 rpm	830 rpm	806 rpm	787 rpm	756 rpm	

BMRS 100		6.22 in ³ /rev (102 cm ³ /rev)					Max Cont.		Max Int.	
Pressure (psi →)		725 psi	1015	1305	1450	1740	2031	2321	2538	2901
FLOW	(gpm ↓)	Torque (in·lbf) Speed Specification								
	1.32	584	814	1062	1195	1381				
		45 rpm	42 rpm	38 rpm	34 rpm	27 rpm				
	2.64	602	850	1106	1221	1407	1664	1876		
		93 rpm	90 rpm	86 rpm	81 rpm	74 rpm	57 rpm	42 rpm		
	5.28	575	832	1089	1213	1372	1646	1859	2106	2425
		189 rpm	185 rpm	180 rpm	173 rpm	165 rpm	158 rpm	150 rpm	139 rpm	118 rpm
	7.93	558	814	1062	1177	1354	1637	1850	2080	2390
		286 rpm	281 rpm	275 rpm	266 rpm	257 rpm	246 rpm	237 rpm	225 rpm	207 rpm
	10.57	504	779	1036	1151	1345	1637	1841	2062	2363
		385 rpm	378 rpm	365 rpm	355 rpm	345 rpm	332 rpm	320 rpm	314 rpm	297 rpm
	13.21	425	699	974	1089	1328	1620	1806	2018	2301
		482 rpm	477 rpm	470 rpm	460 rpm	448 rpm	435 rpm	420 rpm	405 rpm	389 rpm
15.85 Max Cont.	336	620	929	1062	1275	1575	1770	1947	2230	
	580 rpm	572 rpm	560 rpm	548 rpm	535 rpm	523 rpm	510 rpm	500 rpm	478 rpm	
18.49	283	575	885	1044	1248	1558	1744	1903	2177	
	678 rpm	670 rpm	660 rpm	648 rpm	638 rpm	626 rpm	615 rpm	606 rpm	580 rpm	
19.82 Max Int.	204	522	823	982	1204	1505	1699	1859	2124	
	728 rpm	720 rpm	710 rpm	695 rpm	681 rpm	667 rpm	650 rpm	634 rpm	618 rpm	

BMRS 125		7.76 in ³ /rev (127.2 cm ³ /rev)					Max Cont.		Max Int.	
Pressure (psi →)		725	1015	1305	1450	1740	2031	2321	2538	2901
FLOW	(gpm ↓)	Torque (in·lbf) Speed Specification								
	1.32	673	974	1283	1478	1673				
		36 rpm	31 rpm	25 rpm	19 rpm	13 rpm				
	2.64	743	1044	1372	1558	1788	2018	2239		
		73 rpm	70 rpm	60 rpm	48 rpm	36 rpm	25 rpm	19 rpm		
	5.28	726	1036	1354	1540	1770	2036	2292	2602	2938
		153 rpm	151 rpm	148 rpm	144 rpm	138 rpm	128 rpm	117 rpm	104 rpm	73 rpm
	7.93	699	1027	1336	1513	1752	2018	2275	2584	2912
		231 rpm	228 rpm	224 rpm	218 rpm	210 rpm	201 rpm	183 rpm	168 rpm	137 rpm
	10.57	637	1009	1310	1487	1735	2000	2266	2567	2894
		309 rpm	307 rpm	303 rpm	298 rpm	292 rpm	280 rpm	270 rpm	252 rpm	218 rpm
	13.21	549	929	1266	1460	1726	1974	2248	2540	2859
		389 rpm	386 rpm	382 rpm	378 rpm	370 rpm	360 rpm	344 rpm	328 rpm	292 rpm
	15.85 Max Cont.	460	867	1204	1416	1690	1947	2213	2496	2823
467 rpm		463 rpm	459 rpm	456 rpm	448 rpm	427 rpm	410 rpm	399 rpm	352 rpm	
18.49	363	797	1151	1381	1655	1903	2142	2460	2770	
	545 rpm	542 rpm	538 rpm	534 rpm	529 rpm	520 rpm	508 rpm	486 rpm	430 rpm	
19.82 Max Int.	283	699	1115	1310	1593	1841	2071	2319	2655	
	586 rpm	583 rpm	578 rpm	570 rpm	560 rpm	546 rpm	532 rpm	520 rpm	480 rpm	

BMRS 160		9.59 in ³ /rev (157.2 cm ³ /rev)					Max Cont.		Max Int.	
Pressure (psi →)		725	1015	1305	1450	1740	2031	2321	2538	2901
FLOW	(gpm ↓)	Torque (in·lbf) Speed Specification								
	1.32	920	1292	1682	1859	2168				
		26 rpm	23 rpm	20 rpm	16 rpm	10 rpm				
	2.64	947	1328	1726	1912	2213	2567	2965		
		59 rpm	56 rpm	50 rpm	45 rpm	37 rpm	30 rpm	22 rpm		
	5.28	903	1336	1752	1947	2275	2638	3027	3275	3717
		121 rpm	118 rpm	115 rpm	113 rpm	108 rpm	102 rpm	97 rpm	90 rpm	78 rpm
	7.93	859	1292	1682	1921	2266	2611	3009	3257	3682
		184 rpm	178 rpm	173 rpm	170 rpm	164 rpm	155 rpm	143 rpm	128 rpm	103 rpm
	10.57	788	1239	1637	1859	2230	2567	2965	3213	3646
		246 rpm	241 rpm	235 rpm	228 rpm	220 rpm	210 rpm	194 rpm	177 rpm	150 rpm
	13.21	637	1133	1584	1788	2160	2514	2894	3169	3620
		310 rpm	307 rpm	300 rpm	295 rpm	287 rpm	278 rpm	262 rpm	247 rpm	210 rpm
	15.85 Max Cont.	531	1027	1505	1752	2124	2469	2841	3115	3540
374 rpm		367 rpm	359 rpm	354 rpm	346 rpm	338 rpm	323 rpm	306 rpm	265 rpm	
18.49	434	947	1452	1708	2062	2399	2735	3045	3452	
	437 rpm	430 rpm	421 rpm	415 rpm	403 rpm	393 rpm	381 rpm	365 rpm	318 rpm	
19.82 Max Int.	319	867	1345	1637	2000	2345	2655	2956	3354	
	472 rpm	463 rpm	450 rpm	441 rpm	431 rpm	420 rpm	405 rpm	389 rpm	365 rpm	

BMRS 200		11.87 in ³ /rev (194.5 cm ³ /rev)					Max Cont.		Max Int.	
Pressure (psi →)		725	1015	1305	1450	1740	2031	2321	2538	2901
FLOW	(gpm ↓)	Torque (in·lbf) Speed Specification								
	1.32	1168	1602	2106	2319	2744				
		24 rpm	22 rpm	18 rpm	13 rpm	10 rpm				
	2.64	1195	1646	2124	2337	2788	3151	3567		
		49 rpm	47 rpm	45 rpm	43 rpm	38 rpm	33 rpm	24 rpm		
	5.28	1159	1620	2106	2301	2779	3169	3576	3877	4408
		99 rpm	97 rpm	94 rpm	92 rpm	88 rpm	83 rpm	74 rpm	64 rpm	56 rpm
	7.93	1115	1575	2062	2248	2753	3142	3558	3815	4301
		149 rpm	147 rpm	144 rpm	141 rpm	135 rpm	126 rpm	113 rpm	105 rpm	91 rpm
	10.57	991	1496	2018	2213	2717	3115	3540	3770	4222
		200 rpm	197 rpm	194 rpm	191 rpm	185 rpm	174 rpm	160 rpm	151 rpm	127 rpm
	13.21	841	1381	1956	2177	2655	3098	3523	3726	4160
		252 rpm	249 rpm	246 rpm	243 rpm	238 rpm	228 rpm	212 rpm	194 rpm	161 rpm
	15.85 Max Cont.	690	1283	1885	2106	2558	3027	3416	3646	4062
304 rpm		301 rpm	298 rpm	294 rpm	286 rpm	276 rpm	262 rpm	243 rpm	218 rpm	
18.49	593	1195	1823	2018	2452	2974	3319	3611	4009	
	355 rpm	353 rpm	349 rpm	340 rpm	329 rpm	316 rpm	300 rpm	288 rpm	257 rpm	
19.82 Max Int.	513	1106	1744	1947	2390	2841	3186	3523	3912	
	382 rpm	379 rpm	373 rpm	362 rpm	350 rpm	337 rpm	322 rpm	312 rpm	278 rpm	

BMRS 250		15.46 in ³ /rev (253.3 cm ³ /rev)						Max Cont.	Max Int.		
Pressure (psi →)		725	1015	1305	1450	1740	2031	2321	2538	2901	
FLOW	(gpm ↓)	Torque (in·lbf) Speed Specification									
	1.32	1549	2151	2691	3027	3602					
		17 rpm	16 rpm	14 rpm	12 rpm	10 rpm					
	2.64	1575	2177	2744	3045	3620	4116	4647			
		37 rpm	35 rpm	31 rpm	28 rpm	23 rpm	18 rpm	11 rpm			
	5.28	1549	2160	2726	3009	3611	4098	4602	4939	5629	
		75 rpm	73 rpm	72 rpm	70 rpm	66 rpm	58 rpm	53 rpm	50 rpm	42 rpm	
	7.93	1434	2080	2691	2938	3540	4027	4567	4868	5496	
		114 rpm	111 rpm	108 rpm	106 rpm	100 rpm	92 rpm	83 rpm	77 rpm	65 rpm	
	10.57	1266	1974	2655	2912	3505	3956	4532	4832	5461	
		154 rpm	152 rpm	150 rpm	147 rpm	143 rpm	132 rpm	120 rpm	110 rpm	90 rpm	
	13.21	1097	1841	2558	2859	3399	3894	4452	4735	5310	
		193 rpm	190 rpm	187 rpm	174 rpm	168 rpm	160 rpm	149 rpm	140 rpm	116 rpm	
	15.85 Max Cont.	912	1699	2478	2779	3284	3770	4328	4549	5116	
233 rpm		230 rpm	227 rpm	224 rpm	218 rpm	205 rpm	190 rpm	181 rpm	155 rpm		
18.49	779	1575	2337	2664	3151	3700	4239	4408	4956		
	273 rpm	270 rpm	267 rpm	263 rpm	252 rpm	242 rpm	226 rpm	209 rpm	173 rpm		
19.82 Max Int.	549	1460	2266	2549	3071	3646	4195	4301	4797		
	294 rpm	291 rpm	287 rpm	283 rpm	274 rpm	263 rpm	249 rpm	236 rpm	211 rpm		

BMRS 315		19.38 in ³ /rev (317.5 cm ³ /rev)						Max Cont.	Max Int.		
Pressure (psi →)		725	1015	1305	1450	1740	2031	2321	2538		
FLOW	(gpm ↓)	Torque (in·lbf) Speed Specification									
	1.32	1903	2673								
		13 rpm	11 rpm								
	2.64	1929	2699	3390	3735	4319	4877	5505			
		28 rpm	27 rpm	25 rpm	24 rpm	21 rpm	18 rpm	13 rpm			
	5.28	1903	2682	3363	3700	4293	4859	5487	5841		
		60 rpm	59 rpm	57 rpm	55 rpm	52 rpm	49 rpm	45 rpm	42 rpm		
	7.93	1806	2620	3319	3655	4248	4797	5425	5788		
		91 rpm	89 rpm	86 rpm	84 rpm	81 rpm	78 rpm	72 rpm	67 rpm		
	10.57	1735	2540	3257	3629	4222	4771	5390	5753		
		122 rpm	120 rpm	117 rpm	112 rpm	106 rpm	100 rpm	94 rpm	85 rpm		
	13.21	1558	2390	3151	3478	4080	4655	5284	5709		
		154 rpm	151 rpm	147 rpm	140 rpm	131 rpm	120 rpm	109 rpm	100 rpm		
	15.85 Max Cont.	1434	2177	3000	3310	3947	4523	5187	5558		
185 rpm		182 rpm	177 rpm	172 rpm	163 rpm	152 rpm	140 rpm	134 rpm			
18.49	1266	2080	2868	3169	3806	4363	4974	5434			
	217 rpm	213 rpm	208 rpm	201 rpm	190 rpm	178 rpm	166 rpm	158 rpm			
19.82 Max Int.	1106	1876	2682	3000	3691	4257	4806	5151			
	232 rpm	228 rpm	222 rpm	216 rpm	208 rpm	200 rpm	183 rpm	171 rpm			

BMRS 375		23.27 in ³ /rev (381.4 cm ³ /rev)						Max Cont.	Max Int.		
Pressure (psi →)		725	1015	1305	1450	1740	2031	2321	2538		
FLOW	(gpm ↓)	Torque (in·lbf) Speed Specification									
	1.32	1354	2053								
		12 rpm	10 rpm								
	2.64	1390	2089	2514	2983	3593	4399	5417	5912		
		24 rpm	23 rpm	22 rpm	21 rpm	19 rpm	17 rpm	15 rpm	12 rpm		
	5.28	1328	2053	2478	2938	3549	4337	5364	5841		
		49 rpm	48 rpm	47 rpm	46 rpm	44 rpm	41 rpm	38 rpm	32 rpm		
	7.93	1257	1903	2425	2894	3523	4275	5337	5771		
		76 rpm	75 rpm	74 rpm	73 rpm	71 rpm	67 rpm	63 rpm	50 rpm		
	10.57	1115	1876	2372	2832	3478	4222	5248	5620		
		103 rpm	101 rpm	99 rpm	97 rpm	95 rpm	92 rpm	88 rpm	70 rpm		
	13.21	929	1655	2142	2673	3328	4027	5160	5381		
		128 rpm	126 rpm	124 rpm	121 rpm	118 rpm	115 rpm	111 rpm	96 rpm		
	15.85 Max Cont.	797	1478	2027	2487	3204	3930	5009	5310		
154 rpm		152 rpm	150 rpm	148 rpm	145 rpm	138 rpm	130 rpm	121 rpm			
18.49	797	1319	1770	2283	3018	3762	4832	5133			
	180 rpm	179 rpm	178 rpm	176 rpm	173 rpm	168 rpm	160 rpm	148 rpm			
19.82 Max Int.	496	1106	1611	2133	2832	3611	4638	5001			
	195 rpm	194 rpm	193 rpm	191 rpm	189 rpm	185 rpm	178 rpm	170 rpm			

BMRS Technical Data

Shaft Seal Rated Pressure

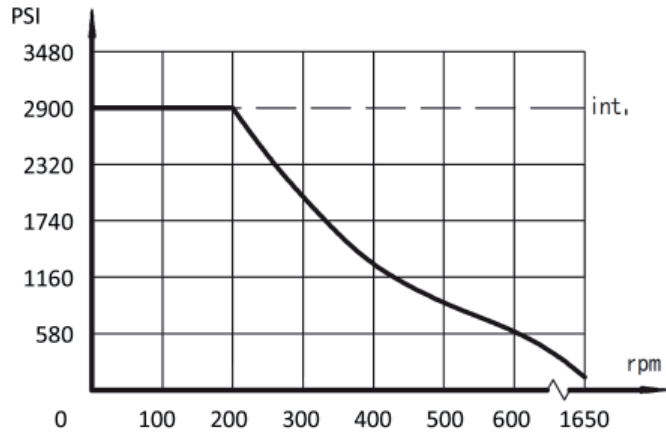
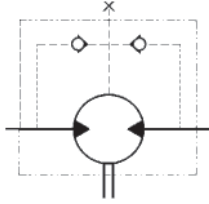

Case Drain

In applications without a motor drain line, the pressure exerted on the shaft seal is marginally in excess of the return line pressure. When the drain line is used, the pressure exerted on the shaft seal is equal to the return line pressure.

Shaft Rotation Direction

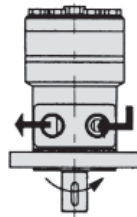

Radial Forces

Status of the Shaft's Radial Force

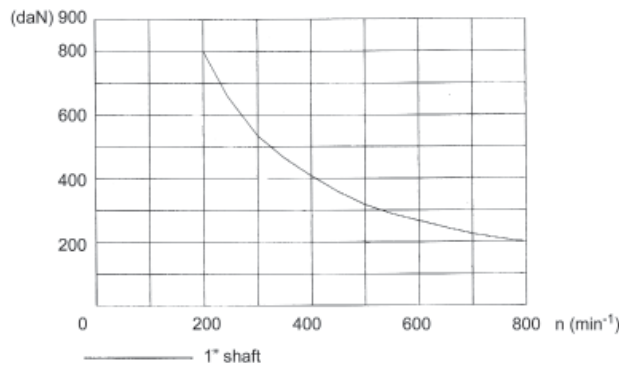

$$F_r = \frac{800}{n} * \frac{25000}{95 + L}$$

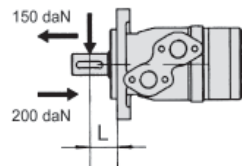

F_r = Radial Force (daN)
 L = Distance (mm)
 n = Speed (rpm)

Rhomb Flange $L=30\text{mm}$
 Square Flange $L=24\text{mm}$



FLUID COMPONENTS, INC.

Hydraulic Motor Model BMSY

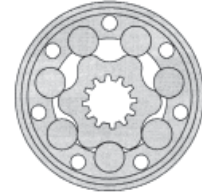
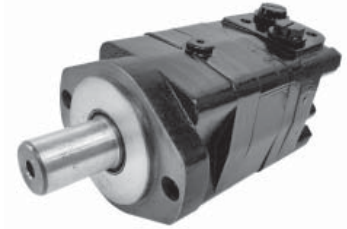

The BMSY series motor adapts the advanced **ROLORTORC™** gear set design with **DISC** distribution flow and high pressure. These motors can be supplied with various options for multifunctional operations in accordance with the application requirements. The output shaft tapered roller bearings permit high axial and radial forces offering a smooth operation during low pressure start up and high pressure operation.

These low weight advanced construction design motors are manufactured in accordance with the requirements of the ISO 9000-2000 quality system.

Technical Specifications

MODEL		BMSY 80	BMSY 100	BMSY 125	BMSY 160	BMSY 200	BMSY 250	BMSY 315	BMSY 400	BMSY 475
Displacement <i>in³/rev (cm³/rev)</i>		4.92 (81)	6.15 (101)	7.63 (125)	9.39 (154)	11.83 (194)	14.83 (243)	18.97 (311)	24.04 (394)	28.98 (475)
Max Speed <i>rpm</i>	Cont	800	748	600	470	375	300	240	185	155
	Int.	988	900	720	560	450	360	280	225	185
Max Torque <i>in•lbf</i>	Cont	1991	2566	3230	4292	5185	6265	7787	7786	8053
	Int.	2212	2832	3540	4778	5707	7142	8495	8495	8495
Max Differential <i>psi</i>	Cont	2973	2973	2973	3045	3045	2900	2900	2320	2030
	Int.	3265	3265	3265	3265	3265	3265	3265	2563	2175
Max Flow <i>gpm</i>	Cont	17.1	19.81	19.81	19.81	19.81	19.81	19.81	19.81	19.81
	Int.	21.13	23.77	23.77	23.77	23.77	23.77	23.77	23.77	23.77
Weight		23.70 lbs	24.05 lbs	24.75 lbs	25.00 lbs	26.15 lbs	27.35 lbs	28.95 lbs	30.95 lbs	32.80 lbs

Continuous = maximum of continuous operation. Intermittent = maximum operating range for 6 seconds per minute

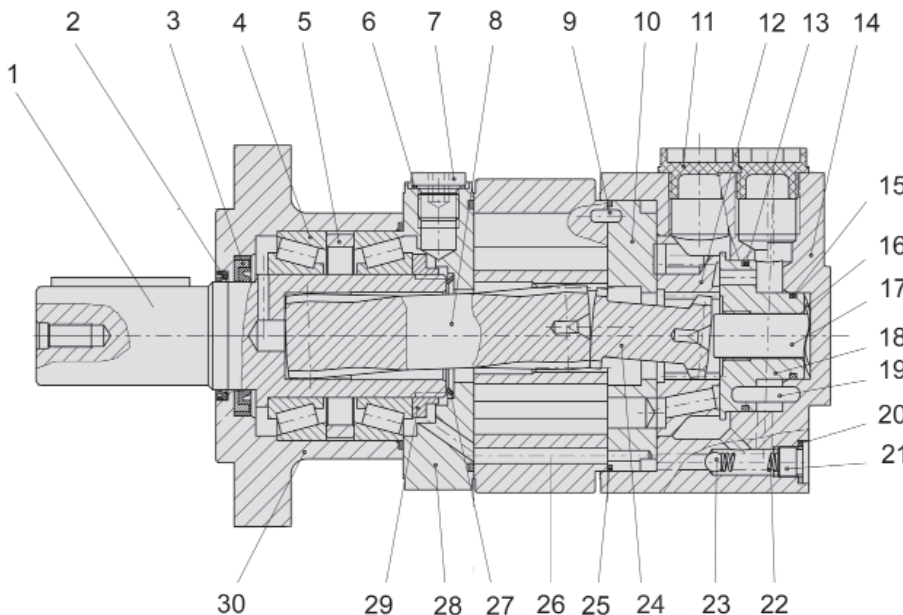
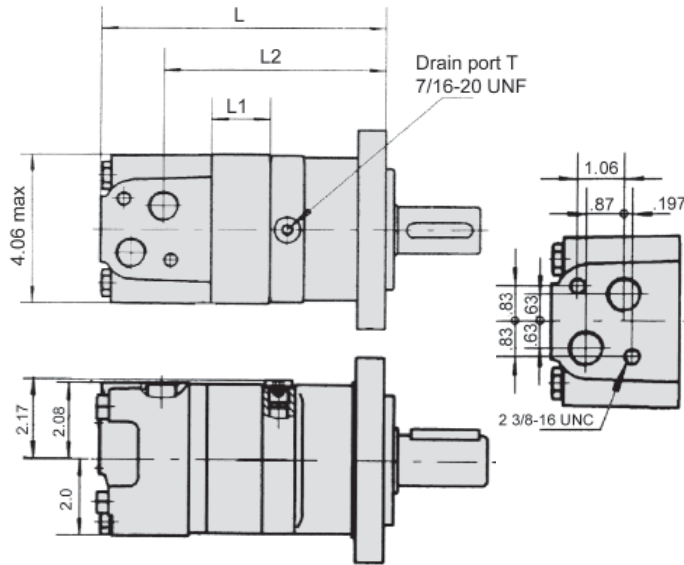

Diagram Key

- | | |
|----------------------|---------------------------|
| 1 Output Shaft | 16 Balancer Spring |
| 2 Dust Seal | 17 Spacer |
| 3 Shaft Seal | 18 Balance Plate |
| 4 Roller Bearing | 19 Pin |
| 5 Bearing Spacer | 20 Seal Washer |
| 6 Seal Washer | 21 Check Valve Plug |
| 7 Case Drain Plug | 22 Check Valve Spring |
| 8 Drive Link | 23 Ball Check (steel) |
| 9 Pin | 24 Distributor Drive Link |
| 10 Timing Plate | 25 Body "O" Ring |
| 11 Shipping Plug | 26 Rolortorc™ Set |
| 12 Distributor Plate | 27 Oil Control Ring |
| 13 "O" Ring | 28 Drain Manifold |
| 14 Rear Housing | 29 Bearing Nut |
| 15 "O" Ring | 30 Shaft Housing |

BMSY Installation Data

S Ports - 7/8-14 UNF



E2 - SAE "A" 2-Bolt

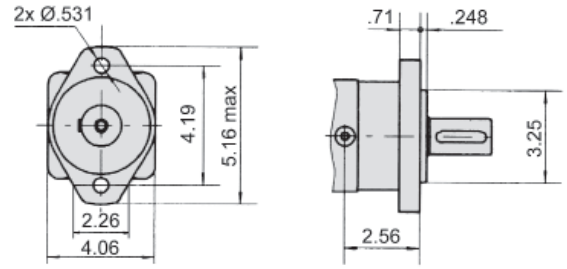

E4 - SAE "A" 4-Bolt

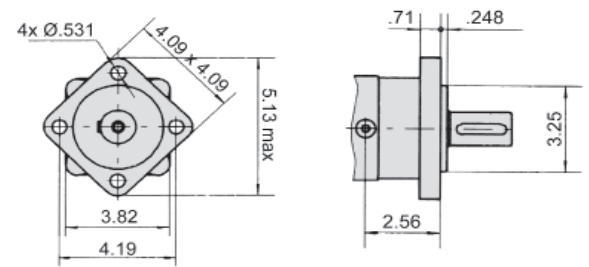

ED Ports (180° Apart) - 1 1/16-12 UNF

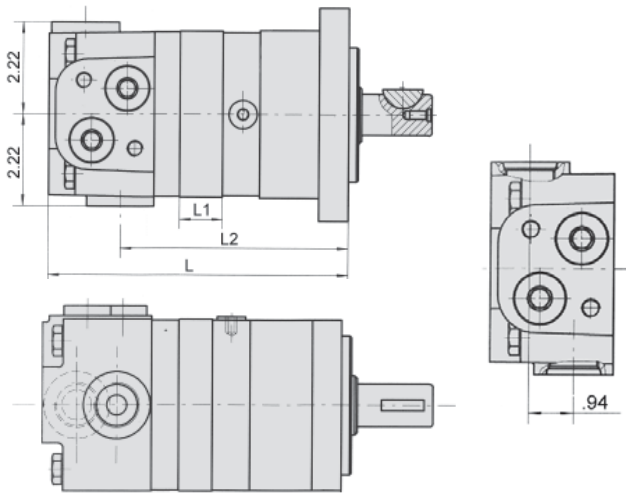

F6 - 6-Bolt Magneto

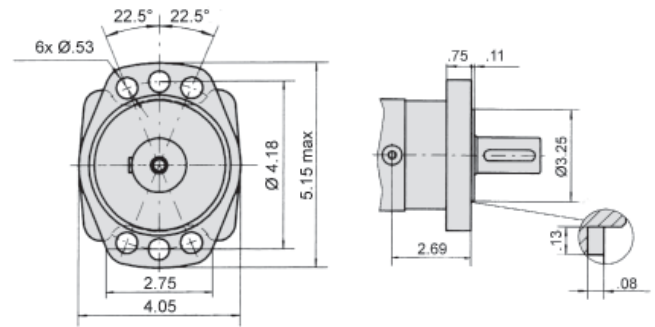

WE - Wheel Mount (4-bolt)

Drop-in replacement for Char-Lynn 105-XXXX series.

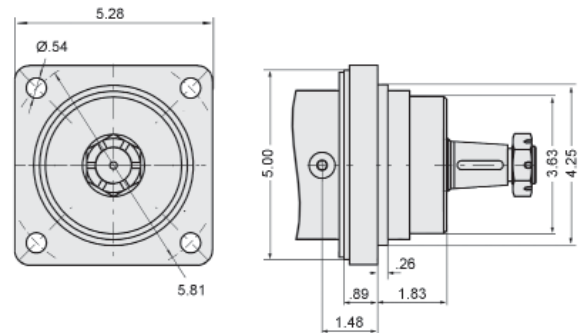

MODEL	E2, E4, F6 Mounts			Wheel Mounts		
	L	L1	L2	L	L1	L2
BMSY 80	6.69	0.63	4.98	5.83	0.63	4.02
BMSY 100	6.85	0.79	5.14	5.98	0.79	4.17
BMSY 125	7.05	0.98	5.33	6.18	0.98	4.37
BMSY 160	7.13	1.06	5.41	6.26	1.06	4.45
BMSY 200	7.40	1.34	5.69	6.54	1.34	4.69
BMSY 250	7.72	1.65	6.00	7.01	1.65	5.00
BMSY 315	8.19	2.13	6.48	7.48	2.13	5.47
BMSY 400	8.78	2.72	7.07	8.07	2.72	6.06
BMSY 475	9.33	3.27	7.62	8.62	3.27	6.61

BMSY Drive Shaft Data

K - 1" Woodruff Key

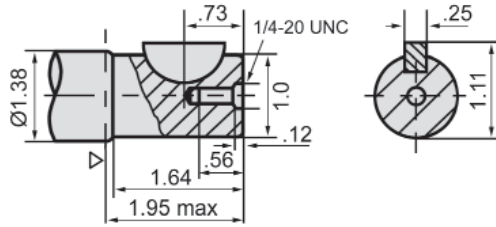

G - 1 1/4" Parallel Key

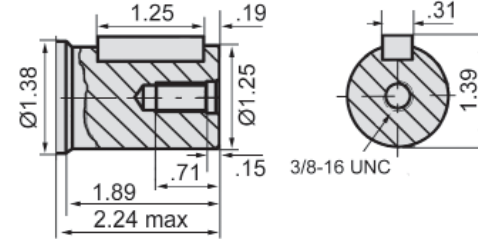

F - 1 1/4" - 14 DP Spline

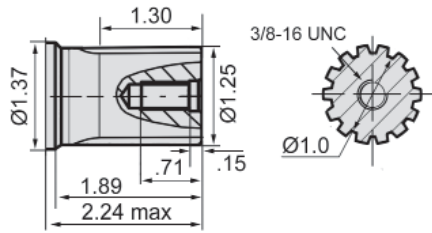

T3 - 1 1/4" Tapered

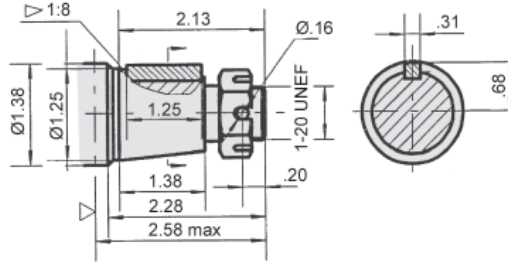

S1 - SAE 6B Spline

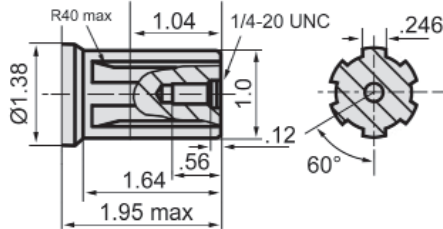

T4 - 1 1/4" Tapered

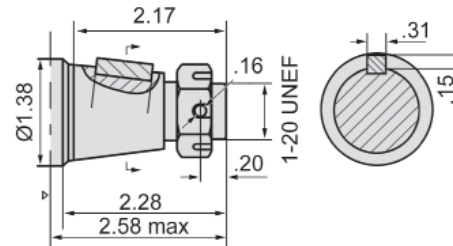

SL - 6 Spline PTO

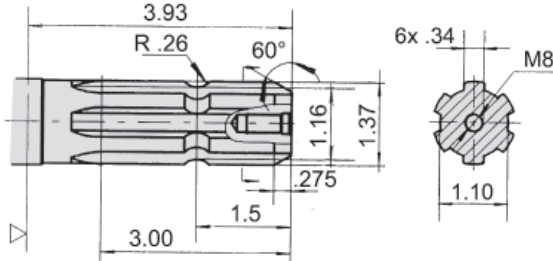

D - 1" Parallel Key

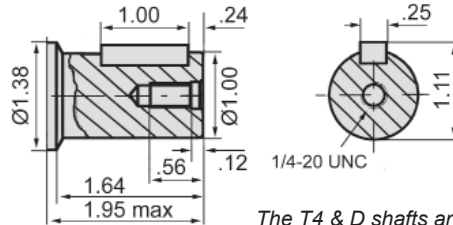

The T4 & D shafts are only available with the Wheel Mount (WE).

Ordering Example:

Model	Frame Size	Flange	Drive Shaft	Ports	Options
BMSY	200	E2	K	S	

Model	Frame Size	Mounting Flange**	Drive Shaft**	Port Size	Options
BMSY	80 (4.92) 100 (6.15) 125 (7.63) 160 (9.59) 200 (11.84) 250 (15.40) 315 (19.20) 400 (24.04) 475 (28.98)	E2 = SAE "A" 2 Bolt E4 = SAE "A" 4-Bolt F6 = Magneto WE = Wheel Mount	K = 1" Woodruff Key G = 1 1/4" Parallel Key S1 = SAE 6B Spline T3 = 1 1/4" Tapered F = 1 1/4" - 14 DP Spline SL* = 6 Spline PTO D*** = 1" Parallel Key T4*** = 1 1/4" Tapered	S = 7/8-14 UNF ED = Side Ports 1 1/16-12 UNF	F* = Free Running * Special order ** Additional flange and drive shaft options available please consult factory. *** The T4 & D shafts are only available with the Wheel Mount (WE).

Seal kits for BMSY Motors are available for purchase. Order seal kit using item description: "BMSY Seal Kit".

BMSY Flow Data

BMSY 80		4.92 in³/rev (80.6 cm³/rev)					<i>Max Cont.</i>	<i>Max Int.</i>	
Pressure (psi →)	515	1030	1546	2060	2576	2973	3308		
FLOW	(gpm ↓)	Torque (in·lbf) Speed Specification							
	3.96	310	708	1062	1398	1726	2017	2204	
		180 rpm	174 rpm	168 rpm	164 rpm	158 rpm	151 rpm	143 rpm	
	7.93	310	708	1062	1398	1726	2053	2301	
		362 rpm	352 rpm	346 rpm	338 rpm	330 rpm	322 rpm	310 rpm	
	10.57	310	699	1053	1372	1708	2009	2213	
		487 rpm	480 rpm	468 rpm	457 rpm	446 rpm	438 rpm	425 rpm	
	13.21	266	681	1035	1354	1699	1982	2195	
		612 rpm	603 rpm	592 rpm	581 rpm	572 rpm	558 rpm	542 rpm	
	15.85	248	681	1035	1354	1699	1982	2150	
735 rpm		726 rpm	718 rpm	703 rpm	687 rpm	673 rpm	646 rpm		
17.17 <i>Max Cont.</i>	230	664	1026	1336	1663	1920	2088		
	794 rpm	786 rpm	773 rpm	760 rpm	744 rpm	722 rpm	706 rpm		
21.13 <i>Max Int.</i>	217	637	964	1256	1557	1823	2009		
	981 rpm	968 rpm	955 rpm	925 rpm	893 rpm	870 rpm	832 rpm		

BMSY 100		6.15 in³/rev (100.8 cm³/rev)					<i>Max Cont.</i>	<i>Max Int.</i>	
Pressure (psi →)	515	1030	1546	2060	2576	2973	3308		
FLOW	(gpm ↓)	Torque (in·lbf) Speed Specification							
	3.96	425	841	1328	1770	2213	2495	2744	
		146 rpm	144 rpm	139 rpm	135 rpm	130 rpm	120 rpm	105 rpm	
	7.93	398	832	1292	1752	2213	2566	2805	
		291 rpm	289 rpm	278 rpm	274 rpm	269 rpm	258 rpm	242 rpm	
	10.57	381	788	1492	1735	2195	2549	2797	
		387 rpm	384 rpm	374 rpm	359 rpm	350 rpm	335 rpm	320 rpm	
	13.21	354	779	1195	1717	2186	2531	2788	
		486 rpm	483 rpm	473 rpm	462 rpm	450 rpm	430 rpm	420 rpm	
	15.85	327	779	1168	1657	2159	2504	2761	
588 rpm		584 rpm	574 rpm	562 rpm	550 rpm	538 rpm	520 rpm		
19.81 <i>Max Cont.</i>	310	708	1151	1593	2124	2469	2744		
	740 rpm	735 rpm	720 rpm	705 rpm	696 rpm	676 rpm	653 rpm		
23.77 <i>Max Int.</i>	266	664	1097	1505	2089	2398	2682		
	850 rpm	840 rpm	810 rpm	787 rpm	770 rpm	750 rpm	747 rpm		

BMSY 125		7.63 in³/rev (125 cm³/rev)					<i>Max Cont.</i>	<i>Max Int.</i>	
Pressure (psi →)	515	1030	1546	2060	2576	2973	3308		
FLOW	(gpm ↓)	Torque (in·lbf) Speed Specification							
	3.96	487	1062	1558	2168	2735	3053	3319	
		115 rpm	113 rpm	110 rpm	104 rpm	98 rpm	90 rpm	84 rpm	
	7.93	487	1062	1549	2213	2787	3221	3575	
		231 rpm	228 rpm	223 rpm	214 rpm	202 rpm	188 rpm	172 rpm	
	10.57	469	1044	1575	2213	2787	3221	3566	
		312 rpm	209 rpm	290 rpm	289 rpm	278 rpm	262 rpm	235 rpm	
	13.21	443	1020	1558	2195	2787	3203	3513	
		391 rpm	386 rpm	378 rpm	365 rpm	352 rpm	339 rpm	308 rpm	
	15.85	398	1000	1513	2133	2726	3168	3513	
469 rpm		461 rpm	450 rpm	437 rpm	425 rpm	400 rpm	372 rpm		
19.81 <i>Max Cont.</i>	398	974	1478	2724	2708	3115	3442		
	588 rpm	574 rpm	560 rpm	544 rpm	526 rpm	505 rpm	481 rpm		
23.77 <i>Max Int.</i>	354	938	1434	2097	2664	6035	3345		
	710 rpm	696 rpm	680 rpm	661 rpm	646 rpm	628 rpm	610 rpm		

BMSY 160		9.39 in³/rev (154 cm³/rev)						<i>Max Cont.</i>	<i>Max Int.</i>
Pressure (psi →)		515	1030	1546	2060	2576	3045	3308	
FLOW	(gpm ↓)	Torque (in·lbf) Speed Specification							
	3.96	620	1257	1904	2639	3295	3852	4216	
		93 rpm	91 rpm	89 rpm	85 rpm	80 rpm	76 rpm	58 rpm	
	7.93	646	1337	1992	2763	3383	4038	4357	
		189 rpm	187 rpm	181 rpm	176 rpm	170 rpm	162 rpm	153 rpm	
	10.57	664	1346	2019	2781	3392	4021	4322	
		252 rpm	250 rpm	246 rpm	239 rpm	234 rpm	228 rpm	212 rpm	
	13.21	620	1310	1992	2701	3294	3941	4251	
		313 rpm	310 rpm	306 rpm	298 rpm	293 rpm	285 rpm	272 rpm	
	15.85	575	1266	1930	2621	3277	3914	4251	
378 rpm		376 rpm	370 rpm	362 rpm	353 rpm	346 rpm	332 rpm		
19.81 <i>Max Cont.</i>	549	1239	1868	2577	3232	3888	4207		
	475 rpm	469 rpm	461 rpm	450 rpm	441 rpm	432 rpm	414 rpm		
23.77 <i>Max Int.</i>	522	1160	1789	2533	3159	3764	4074		
	567 rpm	561 rpm	554 rpm	543 rpm	532 rpm	520 rpm	509 rpm		

BMSY 200		11.8 in³/rev (194 cm³/rev)						<i>Max Cont.</i>	<i>Max Int.</i>
Pressure (psi →)		515	1030	1546	2060	2576	3045	3308	
FLOW	(gpm ↓)	Torque (in·lbf) Speed Specification							
	3.96	771	1585	2737	3286	4171	4977	5403	
		74 rpm	73 rpm	71 rpm	68 rpm	64 rpm	60 rpm	48 rpm	
	7.93	806	1682	2550	3418	4331	5066	5473	
		150 rpm	148 rpm	143 rpm	140 rpm	134 rpm	128 rpm	119 rpm	
	10.57	832	1709	2621	3489	4410	5172	5712	
		198 rpm	195 rpm	192 rpm	188 rpm	183 rpm	178 rpm	167 rpm	
	13.21	797	1691	2586	3445	4366	5137	5615	
		248 rpm	246 rpm	241 rpm	236 rpm	230 rpm	223 rpm	212 rpm	
	15.85	752	1638	2471	3383	4277	5092	5509	
300 rpm		295 rpm	288 rpm	281 rpm	273 rpm	263 rpm	251 rpm		
19.81 <i>Max Cont.</i>	690	1558	2400	3277	4180	4968	5402		
	374 rpm	370 rpm	364 rpm	360 rpm	352 rpm	340 rpm	331 rpm		
23.77 <i>Max Int.</i>	602	1443	2347	3197	4038	4827	5305		
	443 rpm	440 rpm	435 rpm	428 rpm	424 rpm	413 rpm	400 rpm		

BMSY 250		14.8 in³/rev (243 cm³/rev)						<i>Max Cont.</i>	<i>Max Int.</i>
Pressure (psi →)		515	1030	1546	2060	2576	2900	3308	
FLOW	(gpm ↓)	Torque (in·lbf) Speed Specification							
	3.96	974	2045	3108	4091	5181	6031	6890	
		59 rpm	58 rpm	56 rpm	53 rpm	50 rpm	46 rpm	35 rpm	
	7.93	1027	2090	3179	4207	5287	6199	6997	
		119 rpm	117 rpm	114 rpm	108 rpm	102 rpm	92 rpm	80 rpm	
	10.57	1045	2134	3215	4251	5305	6253	7050	
		162 rpm	159 rpm	156 rpm	150 rpm	143 rpm	134 rpm	121 rpm	
	13.21	983	2072	3117	4180	5234	6137	6979	
		203 rpm	201 rpm	197 rpm	191 rpm	182 rpm	173 rpm	158 rpm	
	15.85	929	1947	3055	4091	5154	6067	6837	
244 rpm		242 rpm	237 rpm	230 rpm	220 rpm	208 rpm	194 rpm		
19.81 <i>Max Cont.</i>	841	1895	3011	4021	5048	5934	6731		
	303 rpm	299 rpm	294 rpm	285 rpm	272 rpm	260 rpm	244 rpm		
23.77 <i>Max Int.</i>	797	1851	2967	3959	4951	5819	6633		
	363 rpm	359 rpm	354 rpm	348 rpm	340 rpm	328 rpm	303 rpm		

BMSY 315		18.9 in³/rev (311 cm³/rev)					<i>Max Cont.</i>	<i>Max Int.</i>	
Pressure (psi →)	515	1030	1546	2060	2538	2900	3308		
FLOW	(gpm ↓)	Torque (in·lbf) Speed Specification							
	3.96	1310	2692	4038	5429	6749	7785	8662	
		48 rpm	47 rpm	45 rpm	43 rpm	41 rpm	39 rpm	27 rpm	
	7.93	1372	2781	4118	5624	6890	7829	8750	
		95 rpm	93 rpm	91 rpm	89 rpm	86 rpm	82 rpm	67 rpm	
	10.57	1417	2843	4242	5757	7050	8024	8830	
		127 rpm	125 rpm	121 rpm	117 rpm	115 rpm	109 rpm	91 rpm	
	13.21	1372	2781	4118	5650	6908	7847	8750	
		159 rpm	157 rpm	153 rpm	149 rpm	145 rpm	142 rpm	128 rpm	
	15.85	1337	2710	4012	5491	6695	7847	8644	
187 rpm		185 rpm	181 rpm	176 rpm	169 rpm	157 rpm	143 rpm		
19.81 <i>Max Cont.</i>	1293	2657	3941	5429	6681	7743	8549		
	238 rpm	236 rpm	232 rpm	227 rpm	224 rpm	220 rpm	196 rpm		
23.77 <i>Max Int.</i>	1194	2513	3858	5318	6549	7637	8425		
	286 rpm	283 rpm	278 rpm	272 rpm	265 rpm	257 rpm	232 rpm		

BMSY 400		24.04 in³/rev (394 cm³/rev)					<i>Max Cont.</i>	<i>Max Int.</i>
Pressure (psi →)	515	1030	1546	2060	2354	2576		
FLOW	(gpm ↓)	Torque (in·lbf) Speed Specification						
	3.96	1646	3354	5115	6894	7930	8726	
		37 rpm	36 rpm	35 rpm	33 rpm	31 rpm	29 rpm	
	7.93	1681	3433	5221	7000	8009	8770	
		75 rpm	73 rpm	71 rpm	68 rpm	65 rpm	61 rpm	
	10.57	1725	3486	5035	7053	8071	8832	
		99 rpm	97 rpm	95 rpm	93 rpm	90 rpm	85 rpm	
	13.21	1690	3433	5194	6947	8000	8699	
		125 rpm	123 rpm	118 rpm	114 rpm	109 rpm	102 rpm	
	15.85	1646	3433	5194	6947	8000	8699	
149 rpm		146 rpm	142 rpm	137 rpm	131 rpm	122 rpm		
19.81 <i>Max Cont.</i>	1601	3292	5097	6814	7885	8611		
	187 rpm	183 rpm	177 rpm	171 rpm	164 rpm	153 rpm		
23.77 <i>Max Int.</i>	1557	3247	5053	6779	7814	8540		
	226 rpm	221 rpm	214 rpm	208 rpm	199 rpm	183 rpm		

BMSY 475		28.9 in³/rev (475 cm³/rev)				<i>Max Cont.</i>	<i>Max Int.</i>	
Pressure (psi →)	515	1030	1546	2060	2207			
FLOW	(gpm ↓)	Torque (in·lbf) Speed Specification						
	3.96	1929	3885	5849	7894	8805		
		30 rpm	29 rpm	28 rpm	27 rpm	25 rpm		
	7.93	1973	3982	5982	8053	8867		
		61 rpm	60 rpm	58 rpm	56 rpm	53 rpm		
	10.57	2017	4079	6097	8203	9000		
		82 rpm	80 rpm	77 rpm	74 rpm	68 rpm		
	13.21	1982	4035	6035	8142	8920		
		103 rpm	101 rpm	97 rpm	92 rpm	86 rpm		
	15.85	1947	3991	5991	8080	8832		
123 rpm		121 rpm	118 rpm	112 rpm	105 rpm			
19.81 <i>Max Cont.</i>	1876	3920	5876	7973	8673			
	155 rpm	153 rpm	147 rpm	140 rpm	132 rpm			
23.77 <i>Max Int.</i>	1734	3725	5690	7761	8487			
	186 rpm	184 rpm	178 rpm	170 rpm	157 rpm			

Shaft Seal Rated Pressure

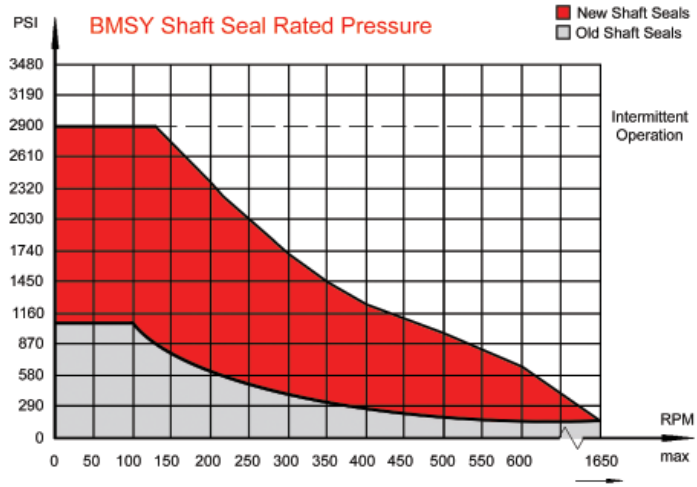
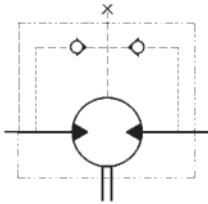

Case Drain

In applications without a motor drain line, the pressure exerted on the shaft seal is marginally in excess of the return line pressure. When the drain line is used, the pressure exerted on the shaft seal is equal to the return line pressure.

Shaft Rotation Direction

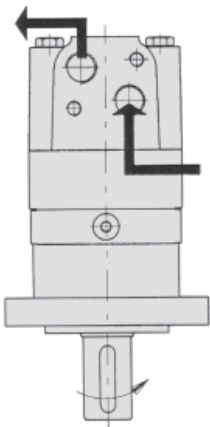

Axial and Radial forces

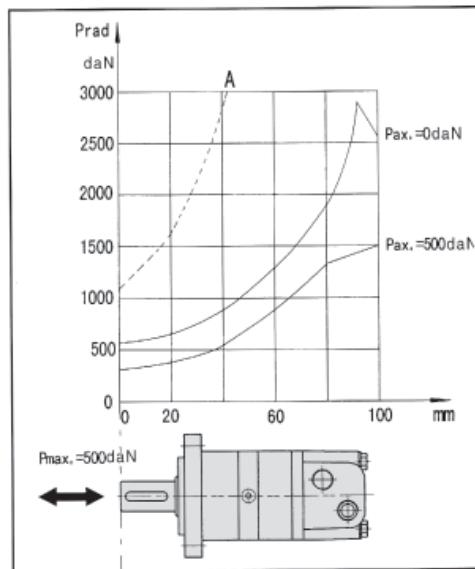

The output shaft runs tapered bearings that permit high axial and radial forces, Curve "A" shows max radial shaft load, Any shaft loads exceeding the values quoted in the curve will involve risk of breakage. The two other curves apply to a B10 bearing life of 3000 hours at 200 rpm.



FLUID COMPONENTS, INC.

Hydraulic Motor Model BMH

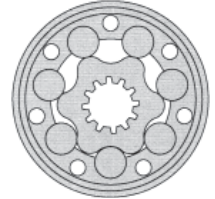

The BMH series advanced **ROLORTORC™** gear set, shaft distribution flow, hydraulic motor is a compact, low noise, high efficient high torque low speed design. The **ROLORTORC™** gear set also affords a reliable smooth start up at low pressure. The special design of the valve linkage and high pressure capability of the shaft seal provides a long operating life and these motors can be used in either series or parallel operation.

The low-weight, advanced-construction design is manufactured in accordance with the requirements of ISO 9000-2000 quality system.

Technical Specifications

MODEL		BMH 200	BMH 250	BMH 315	BMH 400	BMH 500
Displacement <i>in³/rev (cm³/rev)</i>		12.40 (203.20)	15.62 (255.90)	19.30 (316.10)	24.80 (406.40)	29.90 (489.20)
Max Speed <i>rpm</i>	Cont	366	290	236	183	155
	Int.	439	348	282	220	166
Max Torque <i>in•lbf</i>	Cont	4513	5496	6549	7646	7071
	Int.	5125	6213	7319	8744	8593
Max Differential <i>psi</i>	Cont	2580	2580	2580	2285	1845
	Int.	2950	2950	2950	2805	2360
Max Flow <i>gpm</i>	Cont	19.75	19.75	19.75	19.75	19.75
	Int.	23.7	23.7	23.7	23.7	23.7
Weight		23.25 lbs	24.20 lbs	25.80 lbs	27.40 lbs	28.50 lbs

Continuous (Cont) = maximum of continuous operation. Intermittent (Int) = maximum operating range for 6 seconds per minute

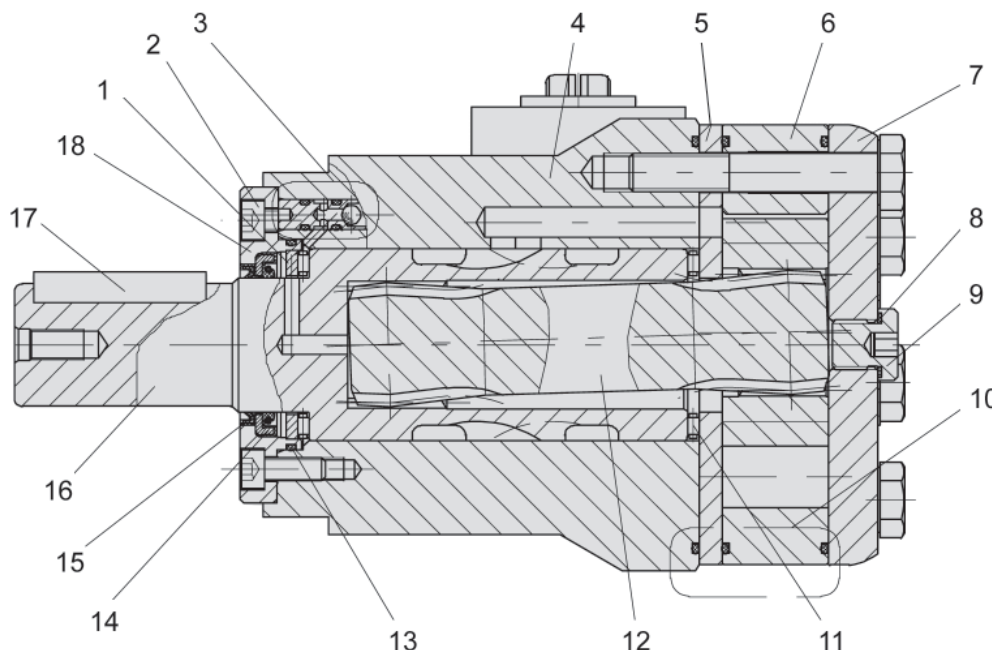
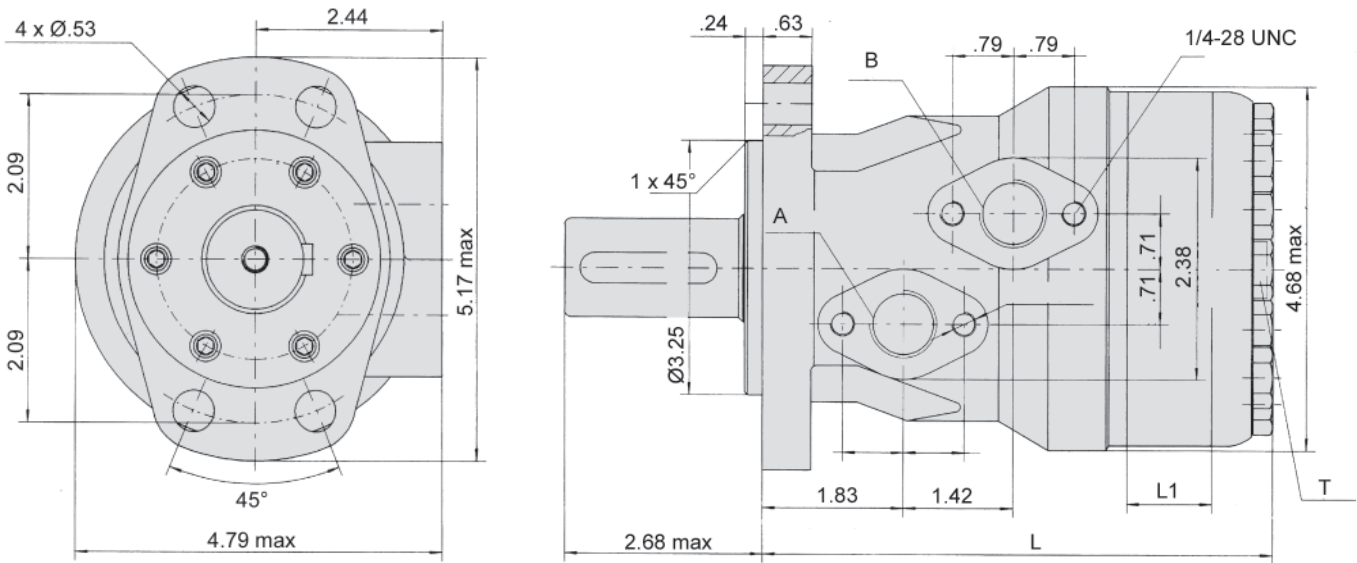

Diagram Key

- 1 Thrust Washer
- 2 Screw
- 3 Check Valve
- 4 Housing
- 5 Wear Plate
- 6 Rolortorc™ Set
- 7 End Cover
- 8 Seal
- 9 Case Drain Plug
- 10 "O" Ring
- 11 Axial Needle Bearing (2)
- 12 Drive Shaft
- 13 "O" Ring
- 14 Shaft Seal
- 15 Dust Seal
- 16 Output Shaft
- 17 Key
- 18 Front Cover

BMH Installation Data



MODEL	L	L1
BMH 200	6.61"	1.06"
BMH 250	6.89"	1.34"
BMH 315	7.24"	1.65"
BMH 400	7.68"	2.12"
BMH 500	8.11"	2.56"

Port	SAE Size	NPT Size
P (A, B)	7/8-14 UNF	1/2-14 NPTF
T	7/16-20 UNF	7/16-20 UNF

BMH Drive Shaft Data

G - 1 1/4" Parallel Key

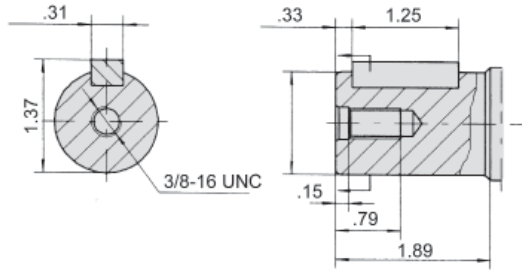

S - SAE 6B Spline

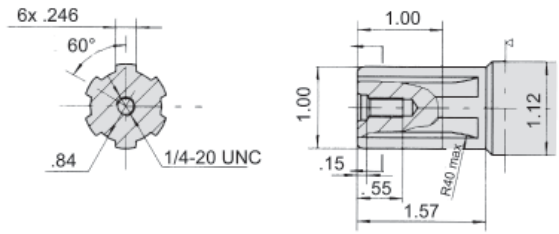

F - 1 1/4" - 14 DP Spline

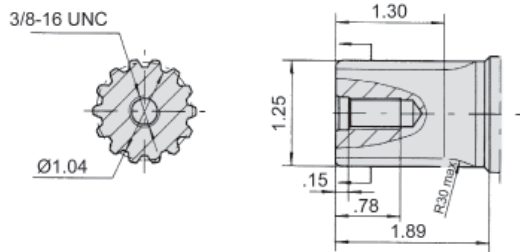

Ordering Example: **BMH** - **315** - **2** - **G** - **P** - **□**

Model	Frame Size	Mounting Flange**	Drive Shaft**	Port Size	Options
BMH	200 (12.40)	4 = Magneto	G = 1 1/4" Parallel Key	P = 1/2-14 NPTF	F* = Free Running
	250 (15.62)	2* = SAE "A" 2-Bolt	S = SAE 6B Spline	S = 7/8-14 UNF	
	315 (19.29)		F = 1 1/4"-14 DP Spline		
	400 (24.80)				
	500 (30.51)				

*Special Order

**Additional flange and drive shaft options available please consult factory.

Seal kits for BMH Motors are available for purchase. Order seal kit using item description: "BMH Seal Kit".

BMH Flow Data

BMH 200							
12.40 in ³ /rev (203.2 cm ³ /rev)							
					Max Cont.	Max Int.	
Pressure (psi →)		515	1030	1546	2060	2576	2950
FLOW	(gpm ↓)	Torque (in•lbf) Speed Specification					
	1.32	867	1717	2513			
		25 rpm	25 rpm	22 rpm			
	2.65	894	1805	2664	3460	4266	
		43 rpm	41 rpm	36 rpm	29 rpm	14 rpm	
	5.26	876	1779	2690	3558	4505	5098
		100 rpm	97 rpm	93 rpm	85 rpm	69 rpm	56 rpm
	7.90	858	1743	2655	3558	4513	5124
		145 rpm	143 rpm	139 rpm	130 rpm	114 rpm	101 rpm
	10.50	797	1681	2584	3531	4487	5115
		200 rpm	200 rpm	200 rpm	188 rpm	168 rpm	153 rpm
	13.15	726	1619	2513	3469	4425	5053
		248 rpm	246 rpm	244 rpm	235 rpm	213 rpm	199 rpm
	15.80	646	1540	2425	3398	4363	4982
292 rpm		290 rpm	287 rpm	279 rpm	260 rpm	244 rpm	
18.40	557	1442	2336	3309	4256	4903	
	352 rpm	350 rpm	349 rpm	338 rpm	318 rpm	301 rpm	
19.75	522	1389	2292	3239	4204	4841	
	366 rpm	365 rpm	363 rpm	355 rpm	335 rpm	319 rpm	
21.05 <i>Max Cont.</i>	469	1328	2239	3168	4124	4761	
	381 rpm	381 rpm	380 rpm	371 rpm	352 rpm	338 rpm	
23.68 <i>Max Int.</i>	345	1239	2133	3080	4036	4655	
	443 rpm	437 rpm	434 rpm	426 rpm	407 rpm	392 rpm	

BMH 250								
15.62 in ³ /rev (255.9 cm ³ /rev)								
					Max Cont.	Max Int.		
Pressure (psi →)		515	1030	1328	1766	2139	2576	2950
FLOW	(gpm ↓)	Torque (in•lbf) Speed Specification						
	1.32	1071	2177	2814	3522			
		19 rpm	19 rpm	18 rpm	14 rpm			
	2.65	1150	2283	2929	3761	4558	5266	
		34 rpm	33 rpm	31 rpm	29 rpm	23 rpm	12 rpm	
	5.26	1150	2283	2938	3823	4602	5496	6213
		78 rpm	77 rpm	76 rpm	73 rpm	65 rpm	53 rpm	42 rpm
	7.90	1080	2221	2894	3797	4602	5496	6195
		115 rpm	113 rpm	111 rpm	105 rpm	96 rpm	84 rpm	75 rpm
	10.50	1017	2124	2858	3735	4540	5452	6177
		157 rpm	157 rpm	156 rpm	150 rpm	139 rpm	127 rpm	114 rpm
	13.15	929	2053	2779	3637	4469	5363	6080
		196 rpm	195 rpm	192 rpm	185 rpm	173 rpm	159 rpm	147 rpm
	15.80	831	1947	2673	3549	4390	5275	5983
232 rpm		230 rpm	226 rpm	218 rpm	206 rpm	192 rpm	180 rpm	
18.40	720	1850	2550	3442	4283	5150	5894	
	274 rpm	274 rpm	274 rpm	266 rpm	252 rpm	238 rpm	222 rpm	
19.75	637	1796	2478	3372	4204	5080	5832	
	290 rpm	289 rpm	287 rpm	279 rpm	266 rpm	251 rpm	236 rpm	
21.05 <i>Max Cont.</i>	584	1717	2416	3283	4133	5009	5761	
	303 rpm	302 rpm	298 rpm	290 rpm	279 rpm	264 rpm	249 rpm	
23.68 <i>Max Int.</i>	433	1575	2266	3142	4009	4885	5611	
	348 rpm	347 rpm	345 rpm	337 rpm	325 rpm	309 rpm	292 rpm	

BMH 315

19.29 in³/rev (316.1 cm³/rev)

Max Cont.

Max Int.

Pressure (psi →)	515	1105	1470	1987	2286	2576	2950	
F L O W	(gpm ↓)	Torque (in·lbf) Speed Specification						
	1.32	1372	2876					
		16 rpm	13 rpm					
	2.65	1442	3026	4018	4921			
		27 rpm	24 rpm	18 rpm	14 rpm			
	5.26	1496	3089	4151	5150	5876	6487	7160
		63 rpm	61 rpm	55 rpm	48 rpm	40 rpm	32 rpm	19 rpm
	7.90	1460	3044	4159	5133	5921	6549	7292
		93 rpm	89 rpm	82 rpm	77 rpm	67 rpm	59 rpm	46 rpm
	10.50	1363	2982	4115	5106	5867	6522	7319
		126 rpm	126 rpm	119 rpm	111 rpm	99 rpm	88 rpm	73 rpm
	13.15	1248	2876	4027	5027	5806	6443	7292
		159 rpm	155 rpm	148 rpm	139 rpm	126 rpm	115 rpm	98 rpm
	15.80	1071	2761	3894	4912	5690	6328	7186
		187 rpm	186 rpm	179 rpm	169 rpm	154 rpm	143 rpm	124 rpm
	18.40	911	2637	3761	4788	5584	6221	7080
222 rpm		222 rpm	215 rpm	205 rpm	187 rpm	176 rpm	157 rpm	
19.75	831	2540	3690	4682	5514	6160	7009	
	236 rpm	233 rpm	224 rpm	215 rpm	196 rpm	184 rpm	166 rpm	
21.05 Max Cont.	726	2451	3593	4584	5407	6089	6938	
	246 rpm	244 rpm	236 rpm	228 rpm	210 rpm	197 rpm	174 rpm	
23.68 Max Int.	549	2266	3416	4390	5248	5921	6788	
	282 rpm	280 rpm	275 rpm	266 rpm	248 rpm	234 rpm	209 rpm	

BMH 400

24.80 in³/rev (406.4 cm³/rev)

Max Cont.

Pressure (psi →)	515	1105	1470	1987	2286	2802	
F L O W	(gpm ↓)	Torque (in·lbf) Speed Specification					
	1.32	1735	3080	4566			
		13 rpm	13 rpm	10 rpm			
	2.65	1814	3212	4832	6213	7602	
		22 rpm	21 rpm	21 rpm	17 rpm	11 rpm	
	5.26	1850	3239	4805	6266	7735	8744
		50 rpm	49 rpm	46 rpm	41 rpm	36 rpm	31 rpm
	7.90	1779	3159	4797	6248	7646	8708
		73 rpm	72 rpm	70 rpm	63 rpm	56 rpm	51 rpm
	10.50	1726	3062	4708	6204	7593	8611
		99 rpm	98 rpm	96 rpm	86 rpm	77 rpm	71 rpm
	13.15	1531	2938	4584	6080	7504	8478
		123 rpm	122 rpm	118 rpm	107 rpm	97 rpm	90 rpm
	15.80	1363	2823	4434	5912	7372	8354
		146 rpm	144 rpm	141 rpm	128 rpm	115 rpm	106 rpm
	18.40	1221	2699	4248	5744	7204	8186
174 rpm		173 rpm	169 rpm	156 rpm	141 rpm	130 rpm	
19.75	1133	2602	4124	5637	7098	8062	
	183 rpm	181 rpm	177 rpm	163 rpm	149 rpm	138 rpm	
21.05 Max Cont.	1000	2451	3991	5496	6956	7956	
	192 rpm	191 rpm	188 rpm	174 rpm	158 rpm	144 rpm	
23.68 Max Int.	796	2266	3832	5266	6788	7797	
	220 rpm	220 rpm	215 rpm	202 rpm	183 rpm	165 rpm	

BMH 500		30.51 in ³ /rev (500 cm ³ /rev)					<i>Max Cont.</i>	<i>Max Int.</i>
Pressure (psi →)		368	738	1254	1470	1840	2355	
F L O W	(gpm ↓)	Torque (in•lbf) Speed Specification						
	1.32	1460	2805	4567				
		11 rpm	11 rpm	8 rpm				
	2.65	1575	2965	4912	5921	7000	8576	
		20 rpm	19 rpm	17 rpm	15 rpm	13 rpm	9 rpm	
	5.26	1566	2929	4947	5956	6894	8744	
		42 rpm	42 rpm	41 rpm	38 rpm	36 rpm	29 rpm	
	7.90	1522	2832	4894	5867	7009	8699	
		64 rpm	63 rpm	61 rpm	57 rpm	53 rpm	47 rpm	
	10.50	1443	2735	4788	5788	6930	8593	
		85 rpm	85 rpm	83 rpm	79 rpm	75 rpm	67 rpm	
	13.15	1292	2120	4628	5620	6797	8443	
		103 rpm	103 rpm	103 rpm	97 rpm	93 rpm	85 rpm	
	15.80	1071	2434	4443	5434	6611	8266	
		124 rpm	124 rpm	123 rpm	117 rpm	113 rpm	103 rpm	
	18.40	858	2266	4266	5283	6452	8115	
148 rpm		148 rpm	148 rpm	140 rpm	134 rpm	122 rpm		
19.75	699	2124	4151	5151	6319	7983		
	155 rpm	155 rpm	155 rpm	152 rpm	144 rpm	130 rpm		
21.05 <i>Max Cont.</i>	531	2000	4009	5044	6204	7823		
	166 rpm	166 rpm	166 rpm	159 rpm	153 rpm	139 rpm		
23.68 <i>Max Int.</i>	301	1779	3726	4868	5956	7691		
	166 rpm	165 rpm	164 rpm	157 rpm	156 rpm	155 rpm		

BMH Technical Data

Shaft Seal Rated Pressure

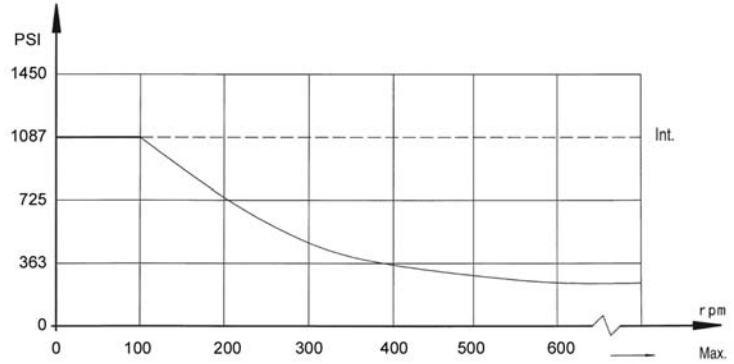
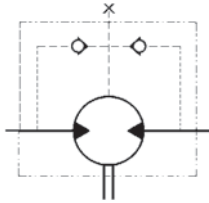

Case Drain

In applications without a motor drain line, the pressure exerted on the shaft seal is marginally in excess of the return line pressure. When the drain line is used, the pressure exerted on the shaft seal is equal to the return line pressure.

Shaft Rotation Direction

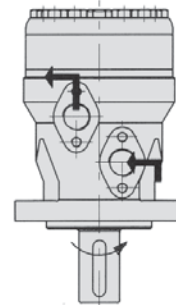

Radial Forces

Status of the Shaft's Radial Force

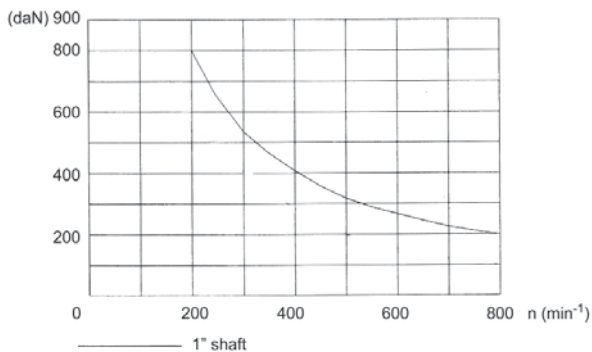

$$F_r = \frac{1100}{n} * \frac{25000}{103.5 + L}$$

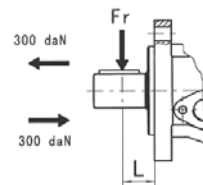

F_r = Radial Force (daN)
 L = Distance (mm)
 n = Speed (rpm)

Rhomb Flange $L=30\text{mm}$
 Square Flange $L=24\text{mm}$

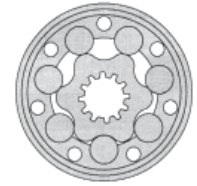

The BMER-2 series motors adapt the Geroler gear set design with high speed distribution flow and high pressure. These motors can be supplied with various options for multifunctional operations in accordance with the application requirements. The output shaft tapered roller bearings permit high axial and radial forces offering a smooth operation during low pressure start up and high pressure operation.

These low weight advanced construction design motors are manufactured in accordance with the requirements of the ISO 9000-2000 quality system.



Technical Specifications

MODEL		BMER 125	BMER 160	BMER 200	BMER 230	BMER 250	BMER 300	BMER 350
Displacement <i>in³/rev (cm³/rev)</i>		7.20 (118)	9.52 (156)	11.96 (196)	13.91 (228)	15.68 (257)	18.08 (296)	21.05 (345)
Max Speed <i>rpm</i>	Cont	360	375	330	290	290	250	220
	Int.	490	470	425	365	350	315	270
Max Torque <i>in•lbf</i>	Cont	2876	3983	4691	5531	6195	7169	8009
	Int.	3363	4646	5310	6284	6992	8231	9160
Max Differential <i>psi</i>	Cont	2973	2973	2973	2973	2973	2973	2973
	Int.	3481	3481	3481	3481	3481	3481	3481
Max Flow <i>gpm</i>	Cont	14.00	15.85	17.96	17.96	19.81	19.81	19.81
	Int.	15.85	19.81	22.45	22.45	23.77	25.09	25.09
Weight		27.45 lbs	29.00 lbs	29.20 lbs	29.45 lbs	30.15 lbs	31.00 lbs	32.00 lbs

MODEL		BMER 375	BMER 400	BMER 475	BMER 540	BMER 650	BMER 750
Displacement <i>in³/rev (cm³/rev)</i>		22.63 (371)	24.71 (405)	28.18 (462)	32.94 (540)	39.48 (647)	45.45 (745)
Max Speed <i>rpm</i>	Cont	200	185	160	140	115	100
	Int.	240	220	195	170	138	120
Max Torque <i>in•lbf</i>	Cont	8762	8939	9602	8673	8983	9293
	Int.	10089	10443	10443	10974	11063	10443
Max Differential <i>psi</i>	Cont	2973	2755	2538	2030	1740	1523
	Int.	3481	2973	2973	2538	2248	1740
Max Flow <i>gpm</i>	Cont	19.81	19.81	19.81	19.81	19.81	19.81
	Int.	23.77	23.77	23.77	23.77	23.77	23.77
Weight		32.35 lbs	33.30 lbs	33.35 lbs	35.10 lbs	36.52 lbs	37.75 lbs

Continuous (Cont.) = maximum of continuous operation. Intermittent (Int.) = maximum operating range for 6 seconds per minute

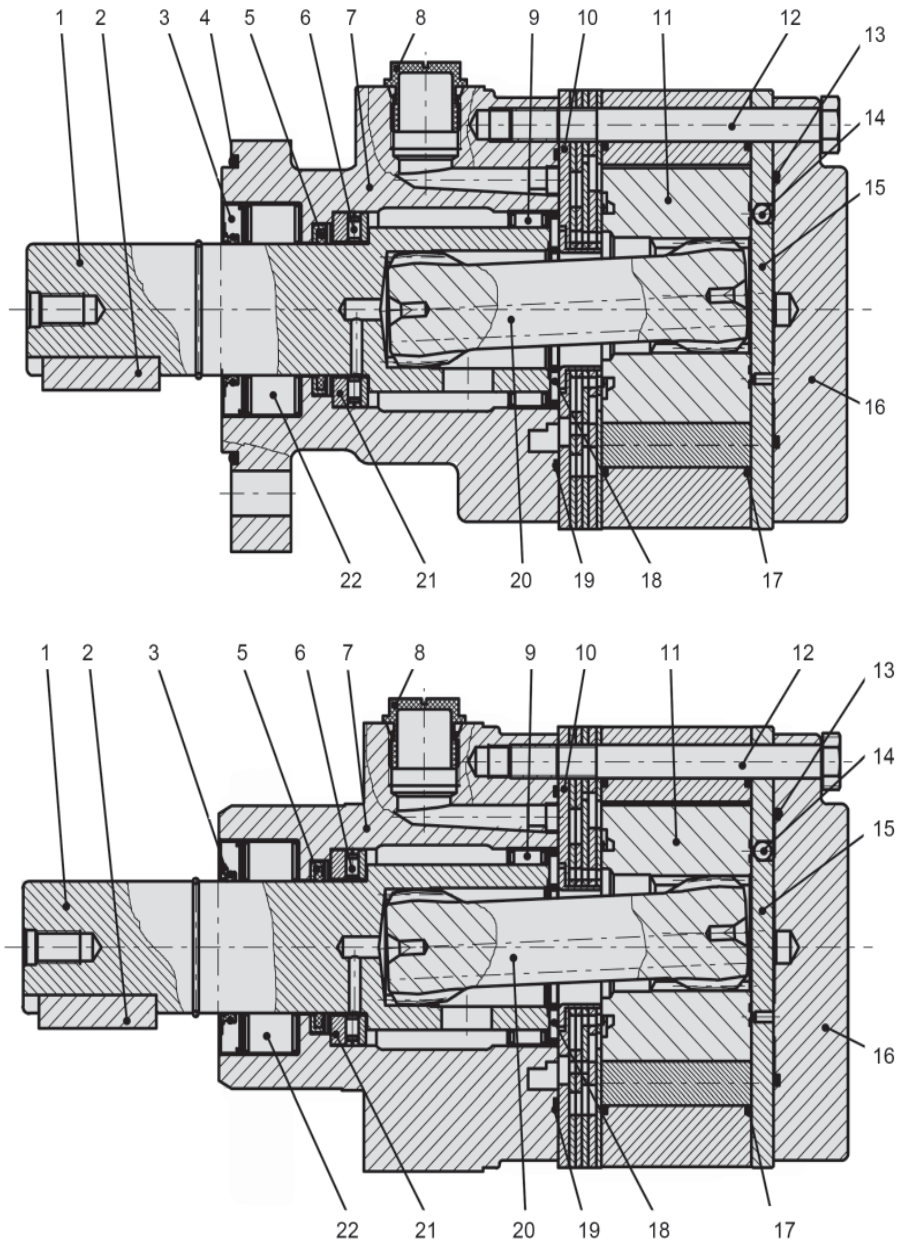
BMER-2**Diagram Key**

1	Output Shaft	12	Bolt
2	Key	13	"O" Ring
3	Dust Seal	14	Ball
4	"O" Ring	15	Balance Plate
5	Shaft Seal	16	End Cover
6	Axial Needle Bearing	17	"O" Ring
7	Housing	18	Axial Needle Bearing
8	Port Plug	19	"O" Ring
9	Radial Needle Bearing	20	Drive Shaft
10	Timing Plate	21	Thrust Washer
11	Rolortorc Gear Set	22	Radial Needle Bearing

BMER-2 Installation Data

WS - Wheel Drive

Motor Size	L	L1
125	4.68"	0.40"
160	4.80"	0.53"
200	4.94"	0.67"
230	5.04"	0.77"
250	5.14"	0.87"
300	5.30"	1.00"
350	5.43"	1.16"
375	5.53"	1.25"
400	5.71"	1.40"
475	5.83"	1.55"
540	6.14"	1.86"
650	6.53"	2.24"
750	6.93"	2.50"

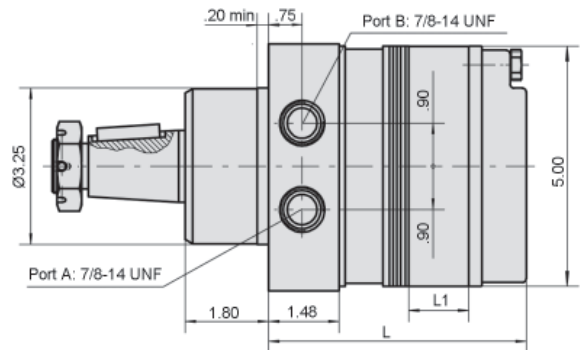
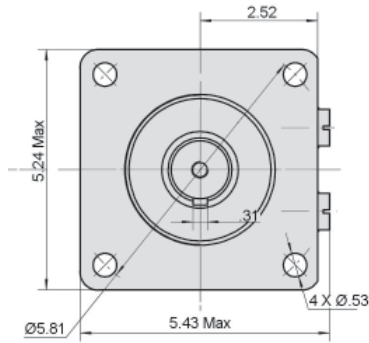

FS - Magneto Mount

Motor Size	L	L1
125	6.18"	0.40"
160	6.30"	0.53"
200	6.44"	0.67"
230	6.54"	0.77"
250	6.63"	0.87"
300	6.77"	1.00"
350	6.93"	1.16"
375	7.03"	1.25"
400	7.16"	1.40"
475	7.32"	1.55"
540	7.64"	1.86"
650	8.03"	2.24"
750	8.27"	2.50"

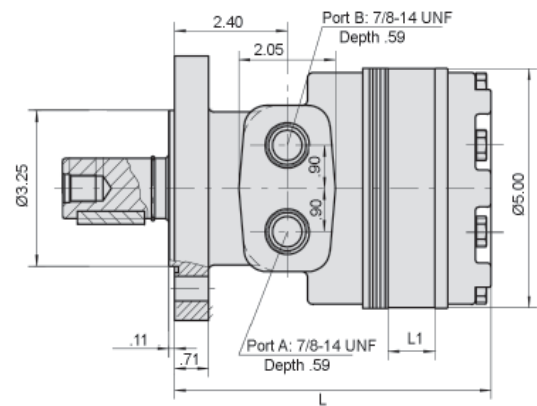
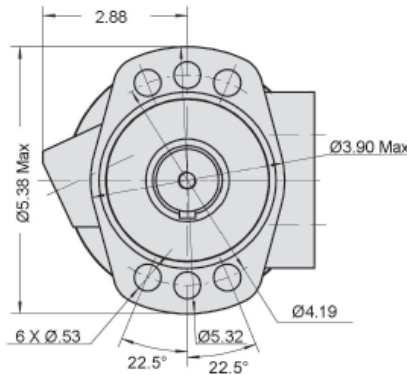

Ordering Example:

Model	Frame Size	Flange	Drive Shaft	Ports	Rotation	Options
BMER-2	375	FS	RW	S		

Model	Frame Size	Mounting Flange	Drive Shaft	Port Size	Rotation
BMER-2	125 (7.20) 160 (9.52) 200 (11.96) 230 (13.91) 250 (15.68) 300 (18.08) 350 (21.05) 375 (22.63) 400 (24.71) 475 (28.18) 540 (32.94) 650 (39.48) 750 (45.45)	WS = Wheel Mount FS = Magneto Mount	RW = 1" Keyed SW = 6B Spline G2 = 1 1/4" Keyed FD1 = 14-Tooth Spline T4 = 1 1/4" Tapered G32 = 1 1/2" Keyed T31 = 1 1/2" Tapered	S = 7/8-14 UNF	Omit = Clockwise R = Counter-Clockwise <i>Note: Direction of rotation is indicated when "A" port is pressurized</i> Options CR = Cavity Valve Relief

*Special Order

**Additional flange and drive shaft options available please consult factory.

Seal kits for BMER-2 motors are available for purchase using item description: "BMER-2 Seal Kit".

BMER-2 Drive Shaft Data

RW - 1" Keyed

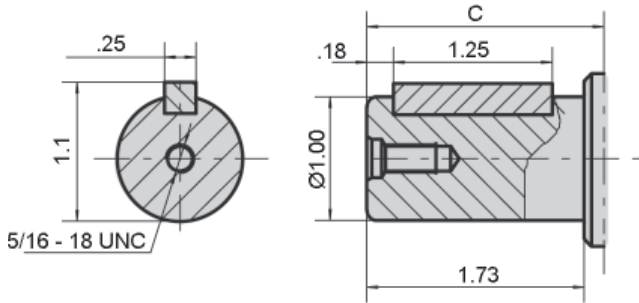

SW - 6B Spline

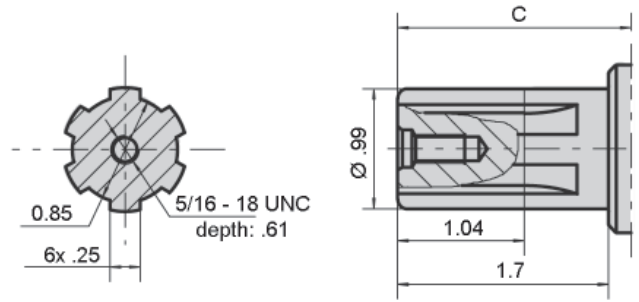

G2 - 1 1/4" Keyed

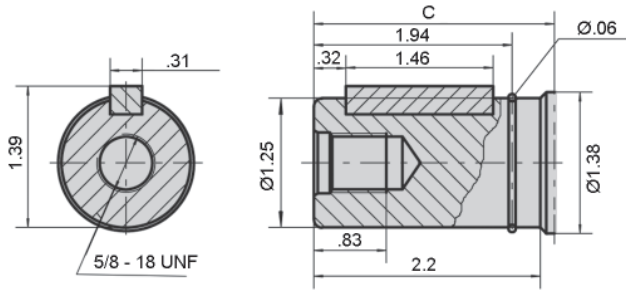

FD1 - 14-Tooth Spline

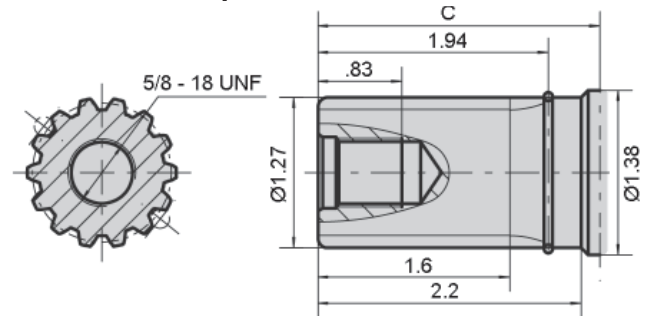

T4 - 1 1/4" Tapered

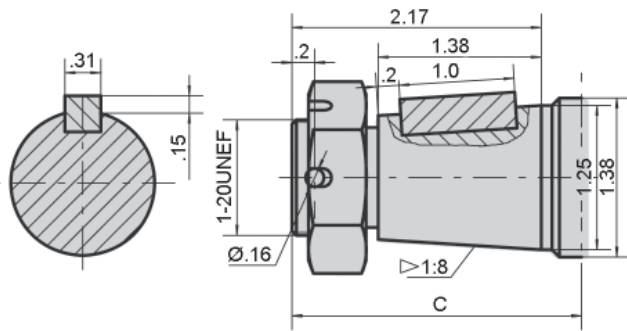

G32 - 1 1/2" Keyed

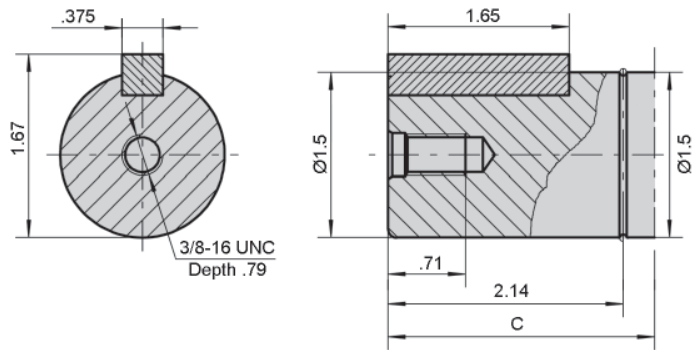

T31 - 1 1/2" Tapered

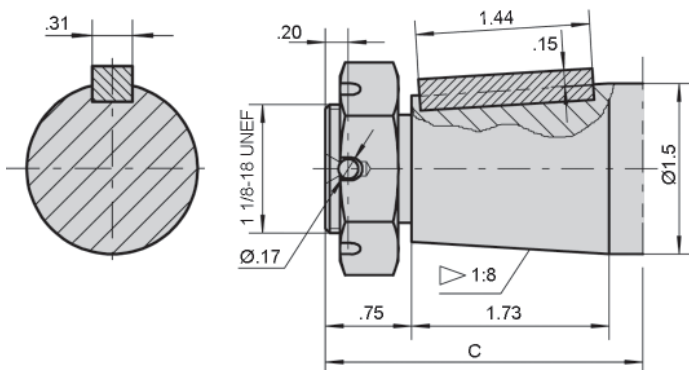

Dimension "C"

From Mounting Flange to Shaft End

Shaft Code	Wheel Mount (WS)	Magneto Mount (FS)
RW	3.58"	1.96"
SW	3.58"	1.96"
G2	4.05"	2.40"
T4	4.21"	2.56"
FD1	4.05"	2.40"
G32	4.23"	2.56"
T31	4.61"	2.93"

BMER Flow Data

BMER-2 125		7.20 in ³ /rev (118 cm ³ /rev)						Max Cont.	Max Int.	
Pressure (psi →)		254	508	1015	1523	2031	2538	2973	3481	
F L O W	(gpm ↓)	Torque (in·lbf) Speed Specification								
	0.53	177	443	850	1212					
		14 rpm	13 rpm	11 rpm	7 rpm					
	1.06	212	469	974	1469	1956				
		28 rpm	26 rpm	24 rpm	19 rpm	13 rpm				
	2.11		487	1000	1540	1991	2354	2602	2974	
			60 rpm	54 rpm	50 rpm	45 rpm	39 rpm	35 rpm	26 rpm	
	3.96		469	1009	1593	2071	2434	2885	3080	
			115 rpm	110 rpm	100 rpm	96 rpm	90 rpm	84 rpm	76 rpm	
	6.60		425	974	1451	2000	2407	2859	3115	
			194 rpm	185 rpm	173 rpm	168 rpm	160 rpm	155 rpm	149 rpm	
	8.98			956	1469	1947	2460	2788	3301	
			276 rpm	260 rpm	244 rpm	232 rpm	225 rpm	217 rpm		
11.88			867	1416	1903	2398	2726	3266		
			362 rpm	350 rpm	342 rpm	325 rpm	322 rpm	303 rpm		
14.00 Max Cont.			797	1345	1841	2345	2690			
			423 rpm	418 rpm	404 rpm	399 rpm	371 rpm			
15.85 Max Int.			726	1248	1814	2301	2655			
			488 rpm	472 rpm	455 rpm	442 rpm	421 rpm			

BMER-2 160		9.52 in ³ /rev (156 cm ³ /rev)						Max Cont.	Max Int.	
Pressure (psi →)		254	508	1015	1523	2031	2538	2973	3481	
F L O W	(gpm ↓)	Torque (in·lbf) Speed Specification								
	0.53	310	655	1292	1929	2637				
		8 rpm	4 rpm	3 rpm	3 rpm	2 rpm				
	1.06	257	699	1389	2080	2797	3275	3752		
		22 rpm	19 rpm	18 rpm	16 rpm	14 rpm	13 rpm	8 rpm		
	2.11	310	690	1398	2089	2761	3301	3983	4655	
		47 rpm	44 rpm	42 rpm	40 rpm	37 rpm	34 rpm	32 rpm	27 rpm	
	3.96	327	655	1372	2071	2744	3257	3894	4575	
		93 rpm	90 rpm	86 rpm	84 rpm	82 rpm	79 rpm	75 rpm	69 rpm	
	6.60		602	1345	2009	2726	3221	3859	4416	
			155 rpm	151 rpm	147 rpm	142 rpm	137 rpm	131 rpm	124 rpm	
	8.98		602	1345	2009	2726	3221	3859	4416	
		214 rpm	213 rpm	210 rpm	204 rpm	198 rpm	191 rpm	184 rpm		
11.88		566	1266	1929	2620	3186	3761	4257		
		282 rpm	280 rpm	275 rpm	268 rpm	263 rpm	256 rpm	245 rpm		
14.00			1195	1912	2593	3159	3726	4213		
			330 rpm	327 rpm	322 rpm	315 rpm	306 rpm	296 rpm		
15.85 Max Cont.			1080	1832	2513	3098	3682	4133		
			379 rpm	376 rpm	368 rpm	362 rpm	356 rpm	345 rpm		
17.96			965	1682	2416	3053	3151			
			423 rpm	419 rpm	414 rpm	406 rpm	394 rpm			
19.81 Max Int.			920	1664	2390	2982	3151			
			472 rpm	466 rpm	460 rpm	450 rpm	436 rpm			

BMER-2 200		11.96 in ³ /rev (196 cm ³ /rev)					Max Cont.	Max Int.		
Pressure (psi →)	254	508	1015	1523	2031	2538	2973	3481		
F L O W	(gpm ↓)	Torque (in·lbf) Speed Specification								
	0.53	345	779	1168	2531	3275				
		8 rpm	4 rpm	4 rpm	3 rpm	2 rpm				
	1.06	372	752	1664	2390	3186	3779	4478		
		16 rpm	14 rpm	13 rpm	11 rpm	10 rpm	9 rpm	6 rpm		
	2.11	381	797	1699	2575	3248	3983	4682	5310	
		35 rpm	32 rpm	29 rpm	28 rpm	27 rpm	25 rpm	23 rpm	19 rpm	
	3.96	336	814	1735	2637	3372	4089	4691	5328	
		74 rpm	71 rpm	68 rpm	64 rpm	60 rpm	58 rpm	55 rpm	50 rpm	
	6.60		726	1664	2505	3336	4036	4673	5354	
			124 rpm	121 rpm	117 rpm	113 rpm	108 rpm	103 rpm	92 rpm	
	8.98		699	1620	2390	3204	3956	4558	5230	
			170 rpm	169 rpm	167 rpm	160 rpm	154 rpm	146 rpm	135 rpm	
	11.88			1443	2292	3115	3903	4514	5248	
				223 rpm	218 rpm	212 rpm	208 rpm	199 rpm	189 rpm	
	14.00			1319	2266	3098	3894	4514	5151	
			260 rpm	258 rpm	254 rpm	248 rpm	241 rpm	230 rpm		
15.85			1168	2195	2974	3823	4434	5089		
			299 rpm	292 rpm	284 rpm	276 rpm	272 rpm	263 rpm		
17.96 <i>Max Cont.</i>			1062	2036	2921	3646	4398	5045		
			336 rpm	332 rpm	327 rpm	319 rpm	310 rpm	301 rpm		
19.81			956	1841	2752	3567	4301			
			375 rpm	372 rpm	365 rpm	358 rpm	350 rpm			
22.44 <i>Max Int.</i>				1628	2478	3363	4088			
				425 rpm	420 rpm	411 rpm	390 rpm			

BMER-2 230		13.91 in ³ /rev (228 cm ³ /rev)					Max Cont.	Max Int.	
Pressure (psi →)	254	508	1015	1523	2031	2538	2973	3481	
F L O W	(gpm ↓)	Torque (in·lbf) Speed Specification							
	0.53	389	797	1611	2575	3310			
		6 rpm	4 rpm	3 rpm	2 rpm	1 rpm			
	1.06	425	885	1912	2744	3584	4283	4859	
		15 rpm	13 rpm	11 rpm	11 rpm	9 rpm	7 rpm	3 rpm	
	2.11	443	920	1876	2832	3726	4584	5337	6195
		31 rpm	29 rpm	27 rpm	25 rpm	23 rpm	20 rpm	16 rpm	10 rpm
	3.96	389	938	1832	2814	3770	4682	5514	6301
		63 rpm	61 rpm	58 rpm	55 rpm	52 rpm	47 rpm	41 rpm	34 rpm
	6.60		894	1850	2867	3788	4708	5487	6239
			103 rpm	100 rpm	96 rpm	92 rpm	87 rpm	81 rpm	71 rpm
	8.98		779	1814	2797	3726	4620	5514	6213
			145 rpm	143 rpm	139 rpm	133 rpm	126 rpm	120 rpm	109 rpm
	11.88			1646	2602	3735	4487	5266	6089
				192 rpm	187 rpm	182 rpm	176 rpm	170 rpm	160 rpm
	14.00			1549	2567	3478	4390	5266	6000
			226 rpm	221 rpm	215 rpm	208 rpm	203 rpm	194 rpm	
15.85			1345	2390	3452	4292	5168	5850	
			256 rpm	253 rpm	248 rpm	242 rpm	235 rpm	222 rpm	
17.96 <i>Max Cont.</i>			1239	2345	3106	4266	5036	5682	
			292 rpm	288 rpm	283 rpm	278 rpm	273 rpm	256 rpm	
19.81			1097	2080	3044	3965	4983		
			324 rpm	321 rpm	314 rpm	308 rpm	300 rpm		
22.44 <i>Max Int.</i>				1832	2965	3912	4832		
				366 rpm	360 rpm	351 rpm	338 rpm		

BMER-2 250		15.68 in ³ /rev (257 cm ³ /rev)						Max Cont.	Max Int.	
Pressure (psi →)	254	508	1015	1523	2031	2538	2973	3481		
FLOW	(gpm ↓)	Torque (in·lbf) Speed Specification								
	0.53	425	982							
		5 rpm	2 rpm							
	1.06	478	1000	2097	3204	4168	5045	5682		
		12 rpm	11 rpm	10 rpm	9 rpm	8 rpm	6 rpm	3 rpm		
	2.11	478	1018	2159	3239	4266	5195	6089		
		27 rpm	26 rpm	24 rpm	22 rpm	20 rpm	18 rpm	14 rpm		
	3.96	443	1000	2266	3248	4292	5230	6124	7027	
		57 rpm	56 rpm	54 rpm	51 rpm	48 rpm	45 rpm	43 rpm	37 rpm	
	6.60	389	1009	2133	3186	4319	5248	6186	6921	
		95 rpm	93 rpm	90 rpm	86 rpm	82 rpm	77 rpm	72 rpm	63 rpm	
	8.98		841	2000	3080	4257	5222	6071	6850	
			129 rpm	125 rpm	121 rpm	116 rpm	111 rpm	106 rpm	96 rpm	
	11.88		681	1903	3062	4142	5062	5965	6894	
			174 rpm	173 rpm	170 rpm	166 rpm	161 rpm	155 rpm	143 rpm	
	14.00		584	1770	2876	3965	4991	5965	6691	
		203 rpm	202 rpm	200 rpm	196 rpm	190 rpm	184 rpm	175 rpm		
15.85			1593	2620	3876	4868	5814	6558		
			232 rpm	229 rpm	225 rpm	220 rpm	215 rpm	202 rpm		
17.96			1434	2602	3673	4850	5682	6461		
			262 rpm	261 rpm	257 rpm	250 rpm	241 rpm	228 rpm		
19.81 <i>Max Cont.</i>			1212	2425	3434	4602	5637	6425		
			290 rpm	289 rpm	278 rpm	280 rpm	273 rpm	260 rpm		
22.44			1151	2310	3275	4505	5345			
			328 rpm	326 rpm	322 rpm	316 rpm	307 rpm			
23.76 <i>Max Int.</i>			752	1982	3168	4337				
			348 rpm	347 rpm	344 rpm	336 rpm				

BMER-2 300		18.06 in ³ /rev (296 cm ³ /rev)						Max Cont.	Max Int.	
Pressure (psi →)	254	508	1015	1523	2031	2538	2973	3481		
FLOW	(gpm ↓)	Torque (in·lbf) Speed Specification								
	0.53	443	823							
		3 rpm	1 rpm							
	1.06	549	1248	2602	3797	4443	5469			
		11 rpm	10 rpm	9 rpm	8 rpm	7 rpm	4 rpm			
	2.11	558	1301	2637	3823	5000	5903	6735	7248	
		22 rpm	21 rpm	20 rpm	19 rpm	16 rpm	13 rpm	9 rpm	5 rpm	
	3.96	584	1274	2699	3779	5027	5938	7169	7912	
		48 rpm	47 rpm	45 rpm	43 rpm	39 rpm	33 rpm	28 rpm	20 rpm	
	6.60	522	1221	2558	3717	4885	5983	7000	8248	
		82 rpm	81 rpm	80 rpm	76 rpm	71 rpm	64 rpm	56 rpm	44 rpm	
	8.98	425	1151	2628	3478	4974	6098	7124	8195	
		113 rpm	112 rpm	110 rpm	107 rpm	102 rpm	96 rpm	86 rpm	73 rpm	
	11.88		850	2372	3407	4664	5629	6664	7788	
			150 rpm	149 rpm	148 rpm	143 rpm	135 rpm	124 rpm	112 rpm	
	14.00		673	2142	3390	4637	5584	6664	7965	
		177 rpm	176 rpm	175 rpm	173 rpm	165 rpm	152 rpm	138 rpm		
15.85		566	1991	3204	4478	5549	6708	7894		
		200 rpm	199 rpm	198 rpm	193 rpm	186 rpm	174 rpm	162 rpm		
17.96			1770	2947	4160	5576	6664	7806		
			225 rpm	224 rpm	222 rpm	212 rpm	201 rpm	194 rpm		
19.81 <i>Max Cont.</i>			1575	2850	4106	5399	6638	7700		
			251 rpm	250 rpm	246 rpm	240 rpm	232 rpm	215 rpm		
22.44			1239	2797	4027	5045	6443			
			285 rpm	284 rpm	278 rpm	270 rpm	257 rpm			
25.08 <i>Max Int.</i>			938	2301	3814	4885	6195			
			316 rpm	314 rpm	311 rpm	307 rpm	292 rpm			

BMER-2 350		21.05 in ³ /rev (345 cm ³ /rev)						Max Cont.	Max Int.
Pressure (psi →)	254	508	1015	1523	2031	2538	2973	3481	
FLOW	(gpm ↓)	Torque (in·lbf) Speed Specification							
	0.53	558	1177						
		4 rpm	4 rpm						
	1.06	566	1195	2567	3894				
		10 rpm	9 rpm	8 rpm	7 rpm				
	2.11	602	1292	2744	4053	5213	6505	7496	
		21 rpm	20 rpm	20 rpm	19 rpm	18 rpm	16 rpm	12 rpm	
	3.96	637	1328	2779	4142	5549	6806	7788	8708
		42 rpm	41 rpm	40 rpm	39 rpm	37 rpm	35 rpm	32 rpm	26 rpm
	6.60	558	1310	2770	4160	5558	6770	7894	9009
		70 rpm	69 rpm	68 rpm	66 rpm	63 rpm	60 rpm	55 rpm	46 rpm
	8.98	460	1177	2690	4027	5478	6726	8009	9151
		97 rpm	96 rpm	95 rpm	93 rpm	89 rpm	85 rpm	78 rpm	68 rpm
	11.88		885	2310	3912	5160	6514	7850	9098
			129 rpm	128 rpm	127 rpm	125 rpm	118 rpm	112 rpm	101 rpm
	14.00		752	2186	3699	5009	6328	7850	9062
		152 rpm	150 rpm	148 rpm	145 rpm	139 rpm	132 rpm	118 rpm	
15.85		575	2505	3629	4868	6301	7788	8815	
		171 rpm	170 rpm	169 rpm	167 rpm	162 rpm	155 rpm	143 rpm	
17.96			1929	3425	4806	6160	7452	8638	
			195 rpm	194 rpm	190 rpm	185 rpm	175 rpm	162 rpm	
19.81 <i>Max Cont.</i>			1823	3301	4558	6018	7301	8549	
			215 rpm	214 rpm	210 rpm	206 rpm	197 rpm	183 rpm	
22.44			1558	3142	4514	6009	7151		
			243 rpm	242 rpm	239 rpm	234 rpm	227 rpm		
25.08 <i>Max Int.</i>				3124	4505	5708			
				272 rpm	269 rpm	265 rpm			

BMER-2 375		22.63 in ³ /rev (371 cm ³ /rev)						Max Cont.	Max Int.
Pressure (psi →)	254	508	1015	1523	2031	2538	2973	3481	
FLOW	(gpm ↓)	Torque (in·lbf) Speed Specification							
	0.53	664							
		3 rpm							
	1.06	735	1416	2921	4319	5629	6735		
		8 rpm	8 rpm	7 rpm	6 rpm	5 rpm	3 rpm		
	2.11	717	1505	3151	4664	6009	7275	8390	9381
		18 rpm	17 rpm	17 rpm	16 rpm	14 rpm	12 rpm	9 rpm	5 rpm
	3.96	673	1434	3151	4717	6045	7478	8655	9753
		39 rpm	38 rpm	37 rpm	35 rpm	32 rpm	29 rpm	25 rpm	18 rpm
	6.60	602	1381	3098	4637	6018	7584	8797	10071
		65 rpm	64 rpm	62 rpm	59 rpm	55 rpm	48 rpm	44 rpm	35 rpm
	8.98	513	1310	3000	4478	6107	7443	8788	10133
		90 rpm	89 rpm	87 rpm	83 rpm	77 rpm	71 rpm	63 rpm	53 rpm
	11.88		1071	2673	4230	5753	7195	8602	10036
			120 rpm	119 rpm	117 rpm	113 rpm	108 rpm	100 rpm	90 rpm
	14.00		841	2496	4124	5558	6947	8602	9762
		141 rpm	140 rpm	138 rpm	134 rpm	128 rpm	120 rpm	105 rpm	
15.85		664	2336	3788	5239	6779	8266	9470	
		161 rpm	161 rpm	160 rpm	158 rpm	155 rpm	151 rpm	141 rpm	
17.96			2053	3735	5177	6691	8186	9434	
			182 rpm	180 rpm	176 rpm	169 rpm	161 rpm	148 rpm	
19.81 <i>Max Cont.</i>			1832	3363	4921	6531	7974	8956	
			201 rpm	200 rpm	195 rpm	190 rpm	181 rpm	165 rpm	
22.44			1579	3275	4655	6195	7363		
			228 rpm	226 rpm	221 rpm	216 rpm	206 rpm		
23.76 <i>Max Int.</i>			1310	2797	4425	5788			
			242 rpm	240 rpm	237 rpm	226 rpm			

BMER-2 400		24.71 in ³ /rev (405 cm ³ /rev)						Max Cont.	Max Int.
Pressure (psi →)	254	508	1015	1523	2031	2538	2756	3263	
F L O W	(gpm ↓)	Torque (in•lbf) Speed Specification							
	0.53	752	1505						
		3	2						
	1.06	797	1611	3257	4779	6328	7832		
		8	7	6	5	4	3		
	2.11	823	1682	3407	5089	6638	7921	8408	10222
		17	16	15	14.4	13	10	9	7
	3.96	779	1593	3363	5089	6638	8009	8673	10310
		36	35	34	33	31	28	24	20
	6.60	779	1593	3363	5089	6638	8098	8939	10310
		60	59	58	56	53	49	44	40
	8.98	664	1460	3230	4956	6638	8098	8850	10443
		83	83	82	81	77	72	68	60
	11.88		1328	3098	4823	6505	7965	8673	10310
			110	110	109	106	102	94	86
	14.00		1106	2921	4646	6372	7832	8496	10178
			130	129	128	125	120	112	100
15.85		885	2699	4469	6018	7611	8319	9956	
		147	147	146	145	142	138	130	
17.96			2434	4248	5841	7478	8186	9735	
			167	167	164	158	150	140	
19.81 Max Cont.			2213	4027	5620	7257	7965	9425	
			184	183	180	176	170	158	
22.44			1991	3673	5310	6947	7655		
			209	208	206	202	194		
23.76 Max Int.			1416	3230	5089	6815			
			220	218	216	210			

BMER-2 475		28.19 in ³ /rev (462 cm ³ /rev)						Max Cont.	Max Int.
Pressure (psi →)	254	508	1015	1523	2031	2538	2973		
F L O W	(gpm ↓)	Torque (in•lbf) Speed Specification							
	0.53	823	1646						
		2 rpm	1 rpm						
	1.06	867	1788	3584	5381	7124			
		7 rpm	6 rpm	5 rpm	5 rpm	4 rpm			
	2.11	867	1823	3806	5770	7469	8894	10443	
		15 rpm	14 rpm	13 rpm	13 rpm	12 rpm	10 rpm	8 rpm	
	3.96	832	1788	3903	5788	7744	9346	10956	
		31 rpm	30 rpm	28 rpm	28 rpm	26 rpm	23 rpm	20 rpm	
	6.60	832	1788	3903	5788	7744	9346	10956	
		52 rpm	51 rpm	48 rpm	45 rpm	43 rpm	39 rpm	35 rpm	
	8.98	664	1593	3717	5841	7523	9602	11204	
		72 rpm	71 rpm	68 rpm	65 rpm	61 rpm	55 rpm	44 rpm	
	11.88		1274	3363	5549	7390	9399	11160	
			96 rpm	95 rpm	93 rpm	90 rpm	84 rpm	73 rpm	
	14.00		1027	3062	5071	7036	8921	10726	
			113 rpm	112 rpm	111 rpm	107 rpm	102 rpm	90 rpm	
15.85		726	2814	4770	6992	8629	10496		
		128 rpm	128 rpm	127 rpm	124 rpm	119 rpm	110 rpm		
17.96		513	2407	4602	6549	8452	10231		
		146 rpm	145 rpm	144 rpm	141 rpm	136 rpm	125 rpm		
19.81 Max Cont.			2036	4248	6213	8142	9877		
			161 rpm	160 rpm	158 rpm	153 rpm	140 rpm		
22.44			1770	4018	5859	7753			
			182 rpm	180 rpm	177 rpm	168 rpm			
23.76 Max Int.			1328	3345	5443	7434			
			194 rpm	193 rpm	190 rpm	182 rpm			

BMER-2 540		32.95 in ³ /rev (540 cm ³ /rev)				Max Cont.	Max Int.
Pressure (psi →)	254	508	1015	1523	2031	2538	
F L O W	(gpm ↓)	Torque (in•lbf) Speed Specification					
	0.53	929	1752				
		2 rpm	2 rpm				
	1.06	1106	2044	4160	6089	8248	10054
		6 rpm	5 rpm	5 rpm	4 rpm	4 rpm	3 rpm
	2.11	1186	2106	4390	6629	8549	10399
		13 rpm	13 rpm	12 rpm	11 rpm	11 rpm	8 rpm
	3.96	1080	(2036	4469	6638	8682	10779
		27 rpm	26 rpm	26 rpm	25 rpm	24 rpm	21 rpm
	6.60	885	1991	4425	6850	8726	10797
		44 rpm	43 rpm	42 rpm	41 rpm	39 rpm	35 rpm
	8.98	708	1876	4257	6620	8646	11001
		62 rpm	61 rpm	60 rpm	58 rpm	54 rpm	49 rpm
	11.88		1531	3867	6319	8284	10532
			82 rpm	82 rpm	81 rpm	79 rpm	75 rpm
	14.00		1257	3682	6000	8301	10355
		97 rpm	97 rpm	96 rpm	94 rpm	89 rpm	
15.85		938	3363	5876	7930	10248	
		110 rpm	110 rpm	109 rpm	108 rpm	106 rpm	
17.96		752	3159	5452	7700	9806	
		125 rpm	124 rpm	124 rpm	123 rpm	120 rpm	
19.81 Max Cont.			2814	5310	7310	9735	
22.44			138 rpm	137 rpm	135 rpm	132 rpm	
			2584	4761	6903		
23.76 Max Int.			154 rpm	153 rpm	152 rpm		
			1894	4301	6682		
			169 rpm	168 rpm	168 rpm		

BMER-2 650		39.48 in ³ /rev (647 cm ³ /rev)				Max Cont.	Max Int.
Pressure (psi →)	254	508	1015	1523	1740	2248	
F L O W	(gpm ↓)	Torque (in•lbf) Speed Specification					
	0.53	1053	2036				
		2	1				
	1.06	1195	2372	4885	7124	8319	
		5	5	4	4	3	
	2.11	1283	2522	5080	7301	8452	11107
		11	11	10	10	9	7
	3.96	1239	2478	5266	7744	8691	11293
		22	22	21	21	20	16
	6.60	1151	2434	5222	7841	8894	11523
		37	36	36	35	34	30
	8.98	1018	2301	5133	7877	8983	11594
		51	51	50	49	47	44
	11.88		2080	4912	7700	8806	11328
			69	68	67	66	63
	14.00		1770	4602	7523	8629	11063
		80	80	79	78	76	
15.85		1505	4337	7301	8275	10753	
		91	91	90	89	88	
17.96		1283	3806	6859	7788	10487	
		104	103	102	101	99	
19.81 Max Cont.			3717	6461	7567	10001	
21.91			114	113	112	110	
			3363	5841	7036		
23.76 Max Int.			130	129	128		
			2567	5177	6461		
			138	137	136		

BMER-2 750

45.46 in³/rev (745 cm³/rev)

Max Cont.

Max Int.

Pressure (psi →)	254	508	1015	1523	1740	2031	
FLOW	(gpm ↓)	Torque (in·lbf) Speed Specification					
	0.53	1283	2478				
		2 rpm	1 rpm				
	1.06	1416	2841	5788	8496	9868	11611
		4 rpm	4 rpm	4 rpm	3 rpm	3 rpm	2 rpm
	2.11	1434	2965	6089	9080	10257	11921
		9 rpm	9 rpm	9 rpm	8 rpm	8 rpm	7 rpm
	3.96	1381	2921	6142	9266	10478	12178
		19 rpm	19 rpm	18 rpm	18 rpm	17 rpm	16 rpm
	6.60	1257	2832	6089	9257	10434	12151
		32 rpm	31 rpm	30 rpm	30 rpm	29 rpm	27 rpm
	8.98	974	2549	5823	9036	10346	12089
		44 rpm	44 rpm	42 rpm	41 rpm	40 rpm	37 rpm
	11.88	628	2142	5487	8691	10116	11903
		60 rpm	59 rpm	59 rpm	58 rpm	58 rpm	55 rpm
	14.00		1788	5027	8328	9779	11576
			70 rpm	69 rpm	68 rpm	67 rpm	66 rpm
	15.85		1239	4664	7947	9611	11381
		79 rpm	78 rpm	77 rpm	76 rpm	74 rpm	
17.96		885	4301	7540	9151	11071	
		90 rpm	90 rpm	89 rpm	88 rpm	87 rpm	
19.81 <i>Max Cont.</i>		575	3761	7186	8673	10425	
		99 rpm	99 rpm	98 rpm	97 rpm	96 rpm	
21.91			3496	6593	8018		
			110 rpm	109 rpm	108 rpm		
23.76 <i>Max Int.</i>			2637	5841	7080		
			120 rpm	119 rpm	117 rpm		

BMER-2 Technical Data

Shaft Rotation Direction: Reverse Timed

- When looking at the shaft end of motor, shaft will rotate:
- Clockwise when port "B" is pressurized.
 - Counter-clockwise when port "A" is pressurized.

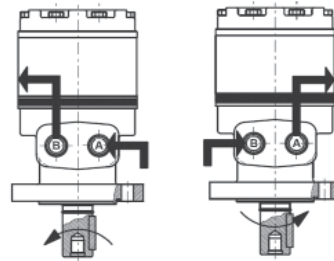

NEW Increased Radial Load Capacity!

Magneto Mount

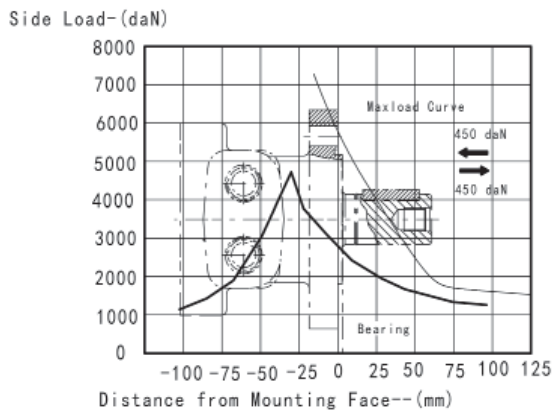

Wheel Mount

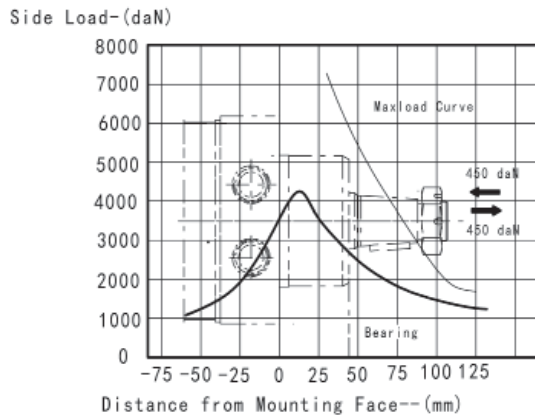

Hydraulic Motor

Model BMER-4

Crossover to White 520/521 Series

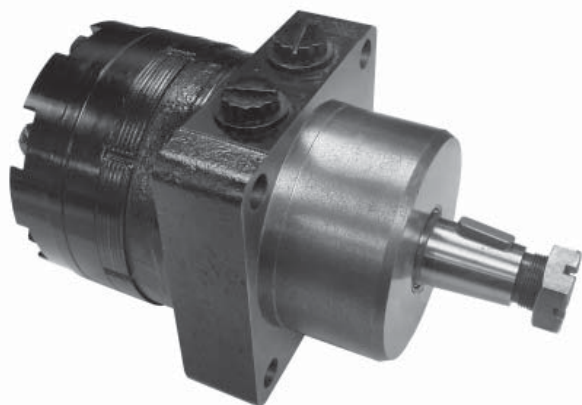

NEW Higher Side Load Capacity!

- High Speed Distribution Flow
- Distribution Range:
7.20 in³/rev to 45.45 in³/rev
- Wheel & Magneto Mount Options
- Extended Shafts Standard

The BMER-4 series motors adapt the Geroler gear set design with high speed distribution flow and high pressure. These motors can be supplied with various options for multifunctional operations in accordance with the application requirements. The output shaft tapered roller bearings permit high axial and radial forces offering a smooth operation during low pressure start up and high pressure operation.

These low weight advanced construction design motors are manufactured in accordance with the requirements of the ISO 9000-2000 quality system.

Consult website, www.dynamicfc.com, for full motor specifications and details.

Ordering Example: **Model** **BMER-4** - **Frame Size** **475** - **Flange** **WS** - **Drive Shaft** **T4E** - **Ports** **S** - **Rotation**

Model	Frame Size	Mounting Flange	Drive Shaft	Port Size	Rotation
BMER-4	125 (7.20) 160 (9.52) 200 (11.96) 230 (13.91) 250 (15.68) 300 (18.08) 350 (21.05) 375 (22.63) 475 (28.18) 540 (32.94) 750 (45.45)	WS = Wheel Mount	RWE = 1" Keyed Ext G2E = 1 1/4" Keyed Ext T4E = 1 1/4" Tapered Ext FD1E = 14-Tooth Spline Ext SWE = 6B Spline Ext G32E = 1 1/2" Keyed Ext T31E = 1 1/2" Tapered Ext	S = 7/8" - 14 SAE	Omit = Clockwise R = Counter-Clockwise <i>Note: Direction of rotation is indicated when "A" port is pressurized</i>

*Special Order

**Additional flange and drive shaft options available please consult factory.

Seal kits for BMER-4 motors are available for purchase. Order seal kits using item description: "BMER-4 Seal Kit".

Hydraulic Motor BMT

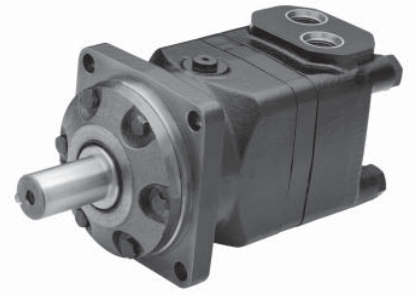

The BMT series motors adapt the advanced **ROLORTORC™** gear set design with **DISC** distribution flow and high pressure. These motors can be supplied with various options for multifunctional operations in accordance with the application requirements. The output shaft tapered roller bearings permit high axial and radial forces offering a smooth operation during low pressure start up and high pressure operation.

These low weight advanced construction design motors are manufactured in accordance with the requirements of the ISO 9000-2000 quality system.

Technical Specifications

MODEL		BMT 160	BMT 200	BMT 250	BMT 315	BMT 400	BMT 500	BMT 630	BMT 800
Displacement	<i>in³/rev (cm³/rev)</i>	9.83 (161.1)	12.29 (201.4)	15.36 (251.8)	19.91 (326.3)	25.07 (410.9)	31.95 (523.6)	38.39 (629.1)	48.93 (801.8)
Max Speed	Cont	614	615	495	380	302	237	196	154
	Int.	770	743	592	458	364	284	233	185
Max Torque	Cont	4168	5213	6434	8514	9691	11018	11664	12956
	Int.	5071	6354	7859	10213	11231	12470	13257	13452
Max Differential	Cont	2944	2944	2944	2944	2650	2355	2060	1840
	Int.	3533	3533	3533	3533	3091	2650	2355	1914
Max Flow	Cont	26.42	33.02	33.02	33.02	33.02	33.02	33.02	33.02
	Int.	33.02	39.63	39.63	39.63	39.63	39.63	39.63	39.63
Weight		44.09 lbs	46.30 lbs	46.30 lbs	46.30 lbs	50.71 lbs	52.91 lbs	55.11 lbs	57.32 lbs

Continuous = maximum of continuous operation. Intermittent = maximum operating range for 6 seconds per minute

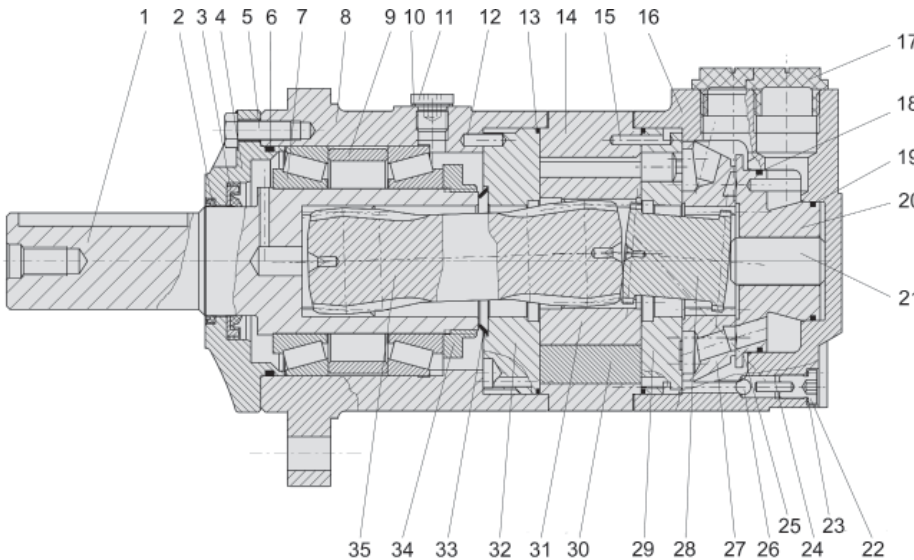

BMT Diagram Key

- | | |
|------------------|-----------------------|
| 1 Output Shaft | 19 "O" Ring |
| 2 Dust Seal | 20 Balance Plate |
| 3 Shaft Seal | 21 Spacer |
| 4 Front Cover | 22 Drain Plug |
| 5 Bolt | 23 Washer |
| 6 "O" Ring | 24 Pin |
| 7 Bearing | 25 Butterfly Ring |
| 8 Housing | 26 Ball Check |
| 9 Spacer Bearing | 27 Distributor Plate |
| 10 Washer | 28 Coupling |
| 11 Drain Plug | 29 Channel Plate |
| 12 Pin | 30 Rolortorc™ set |
| 13 "O" Ring | 31 Rotor |
| 14 Stator | 32 Intermediate Plate |
| 15 Rotor | 33 Butterfly Washer |
| 16 End Cover | 34 Lock Nut |
| 17 Drain Plug | 35 Drive Shaft |
| 18 "O" Ring | |

BMT Installation Data

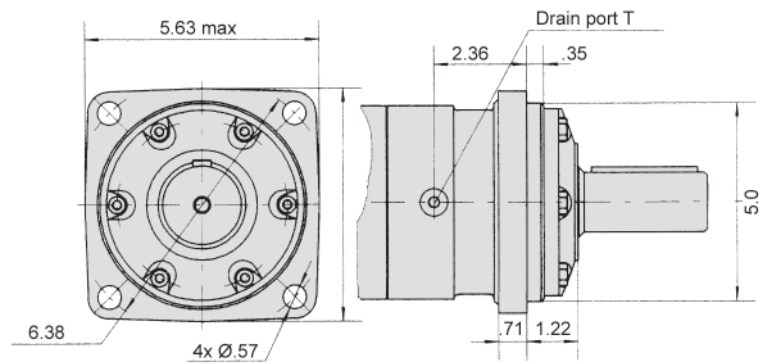
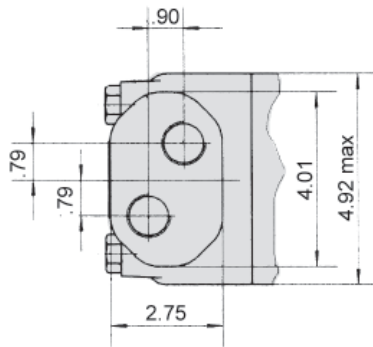
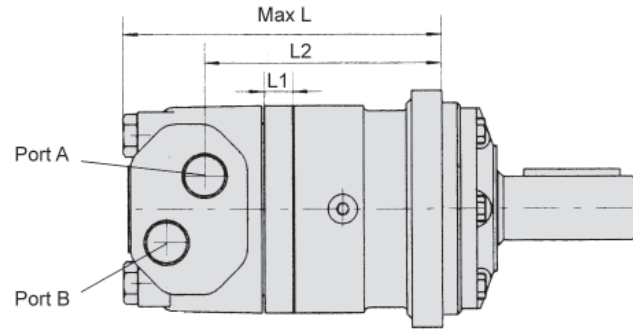
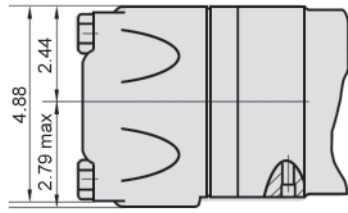

MODEL	L	L1	L2
BMT 160	7.60"	0.67"	5.61"
BMT 200	7.76"	0.83"	5.77"
BMT 250	8.03"	0.55"	6.00"
BMT 315	8.27"	0.79"	6.24"
BMT 400	8.54"	1.06"	6.52"
BMT 500	8.86"	1.38"	6.83"
BMT 630	9.33"	1.85"	7.30"
BMT 800	9.76"	2.28"	7.73"

Port	Port Size
P (A, B)	1 1/16-12 UNF
T	7/16-20 UNF

BMT Drive Shaft Data

G1 - 1 1/4" Parallel Key

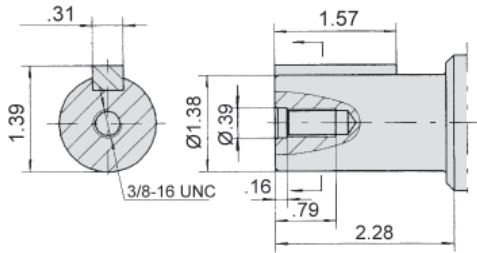

F1 - 1 1/4" - 14-Tooth DP Spline

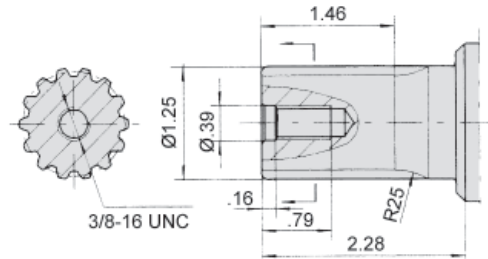

G - 1 1/2" Parallel Key

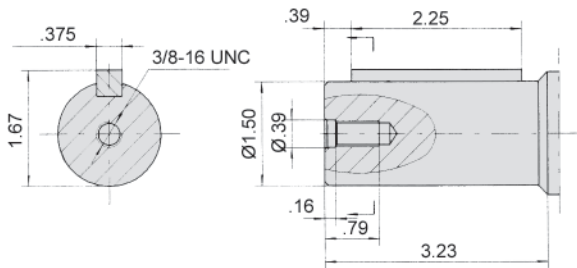

F - 1 1/2" - 17-Tooth DP Spline

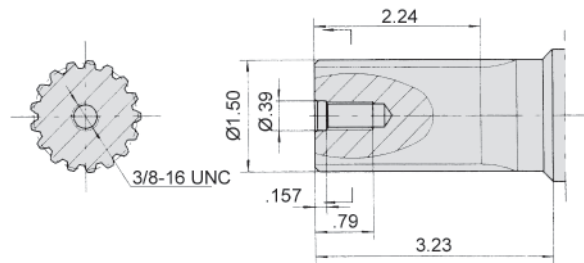

Ordering Example:

Model	Frame Size	Flange	Drive Shaft	Ports	Options
BMT	400	K6	G	S1	

Model	Frame Size	Mounting Flange**	Drive Shaft**	Port Size	Options
BMT	160 (9.83) 200 (12.29) 250 (15.36) 315 (19.91) 400 (25.07) 500 (31.95) 630 (38.39) 800 (48.93)	K6 = 4-Bolt	G1 = 1 1/4" Parallel Key G = 1 1/2" Parallel Key F1 = 1 1/4" - 14 DP Spline F = 1 1/2" - 17 DP Spline	S1 = 1 1/16-12 UNF	1* = Free Running

* Special Order

** Additional flange and drive shaft options available. Please consult factory.

Seal kits for BMT Motors are available for purchase. Order seal kit using item description: "BMT Seal Kit".

BMT Flow Data

BMT 160		9.83 in ³ /rev (161.1 cm ³ /rev)					Max Cont.	Max Int.
Pressure (psi →)		588	1175	1470	1766	2355	2950	3535
F L O W	(gpm ↓)	Torque (in•lbf) Speed Specification						
	2.64	780	1558	2081	2434	3195	3956	4735
		60 rpm	59 rpm	58 rpm	56 rpm	54 rpm	50 rpm	44 rpm
	5.28	788	1602	2071	2451	3292	4062	4929
		121 rpm	120 rpm	117 rpm	114 rpm	109 rpm	103 rpm	95 rpm
	10.57	805	1593	2080	2451	3372	4168	5071
		249 rpm	246 rpm	243 rpm	236 rpm	230 rpm	223 rpm	212 rpm
	15.85	726	1575	2080	2451	3372	4160	5063
		371 rpm	367 rpm	362 rpm	356 rpm	349 rpm	340 rpm	330 rpm
	21.13	690	1531	2027	2443	3356	4124	5018
492 rpm		489 rpm	485 rpm	478 rpm	470 rpm	462 rpm	447 rpm	
26.42 Max Cont.	620	1416	1929	2380	3275	4026	4938	
	614 rpm	611 rpm	606 rpm	598 rpm	590 rpm	582 rpm	570 rpm	
33.02 Max Int.	513	1309	1867	2310	3177	3965	4885	
	770 rpm	764 rpm	758 rpm	750 rpm	741 rpm	731 rpm	715 rpm	

BMT 200		12.29 in ³ /rev (201.4 cm ³ /rev)					Max Cont.	Max Int.
Pressure (psi →)		588	1175	1470	1766	2355	2950	3535
F L O W	(gpm ↓)	Torque (in•lbf) Speed Specification						
	2.64	1097	2062	2558	3009	4018	4956	5921
		47 rpm	46 rpm	45 rpm	42 rpm	39 rpm	37 rpm	33 rpm
	5.28	1106	2715	2637	3071	4142	5098	6160
		95 rpm	94 rpm	92 rpm	90 rpm	87 rpm	84 rpm	75 rpm
	10.57	1062	2133	2620	3115	4204	5213	6337
		195 rpm	193 rpm	191 rpm	187 rpm	183 rpm	178 rpm	167 rpm
	15.85	1027	2097	2611	3115	4231	5213	6355
		297 rpm	295 rpm	292 rpm	287 rpm	282 rpm	276 rpm	263 rpm
	21.13	956	2044	2558	3098	4195	5187	6337
395 rpm		393 rpm	389 rpm	384 rpm	377 rpm	370 rpm	259 rpm	
26.42	871	2009	2531	3045	4169	5133	6302	
	493 rpm	490 rpm	486 rpm	482 rpm	475 rpm	467 rpm	460 rpm	
33.02 Max Cont.	743	1841	2443	2947	4062	5009	6169	
	615 rpm	611 rpm	607 rpm	602 rpm	595 rpm	588 rpm	572 rpm	
39.63 Max Int.	620	1717	2301	2868	3956	4903	6036	
	743 rpm	740 rpm	735 rpm	727 rpm	717 rpm	706 rpm	682 rpm	

BMT 250		15.36 in ³ /rev (251.8 cm ³ /rev)					Max Cont.	Max Int.
Pressure (psi →)		588	1175	1470	1766	2355	2950	3535
FLOW	(gpm ↓)	Torque (in•lbf) Speed Specification						
	2.64	1221	2531	3142	3708	4947	6098	7292
		38 rpm	38 rpm	37 rpm	36 rpm	34 rpm	32 rpm	31 rpm
	5.28	1266	2620	3221	3823	5133	6266	7550
		76 rpm	75 rpm	74 rpm	72 rpm	70 rpm	67 rpm	62 rpm
	10.57	1230	2664	3297	3894	5248	6400	7823
		156 rpm	154 rpm	152 rpm	149 rpm	146 rpm	142 rpm	134 rpm
	15.85	1168	2602	3292	3903	5239	6434	7860
		237 rpm	236 rpm	233 rpm	229 rpm	224 rpm	219 rpm	207 rpm
	21.13	1133	2505	3221	3832	5195	6381	7850
317 rpm		316 rpm	314 rpm	308 rpm	303 rpm	299 rpm	284 rpm	
26.42	1115	2496	3142	3779	5151	6337	7779	
	396 rpm	394 rpm	391 rpm	387 rpm	381 rpm	373 rpm	359 rpm	
33.02 Max Cont.	1027	2301	3010	3665	5027	6222	7646	
	485 rpm	492 rpm	488 rpm	483 rpm	476 rpm	469 rpm	454 rpm	
39.63 Max Int.	779	2142	2832	3513	4885	6071	7496	
	592 rpm	589 rpm	585 rpm	580 rpm	572 rpm	565 rpm	545 rpm	

BMT 315		19.91 in ³ /rev (326.3 cm ³ /rev)					Max Cont.	Max Int.
Pressure (psi →)		588	1175	1470	1766	2355	2950	3535
FLOW	(gpm ↓)	Torque (in•lbf) Speed Specification						
	2.64	1628	3213	4009	4823	6496	7885	9399
		30 rpm	29 rpm	28 rpm	27 rpm	26 rpm	25 rpm	23 rpm
	5.28	1673	3363	4177	4975	6700	8115	9815
		60 rpm	59 rpm	58 rpm	56 rpm	54 rpm	52 rpm	50 rpm
	10.57	1690	3372	4283	5045	6850	8445	10170
		121 rpm	120 rpm	118 rpm	115 rpm	112 rpm	109 rpm	104 rpm
	15.85	1673	3328	4363	5070	6832	8514	10213
		183 rpm	181 rpm	179 rpm	175 rpm	172 rpm	168 rpm	158 rpm
	21.13	1584	3266	4240	5000	6797	8443	10204
244 rpm		242 rpm	239 rpm	236 rpm	231 rpm	227 rpm	217 rpm	
26.42	1496	3160	4133	4975	6708	8357	10116	
	305 rpm	304 rpm	301 rpm	298 rpm	294 rpm	289 rpm	276 rpm	
33.02 Max Cont.	1301	2975	3955	4815	6595	8145	9975	
	380 rpm	378 rpm	375 rpm	371 rpm	367 rpm	362 rpm	349 rpm	
39.63 Max Int.	1053	8950	3825	4655	6310	7912	9710	
	458 rpm	456 rpm	453 rpm	449 rpm	444 rpm	431 rpm	425 rpm	

BMT 400		25.07 in ³ /rev (410.9 cm ³ /rev)					Max Cont.	Max Int.
Pressure (psi →)		440	880	1325	1766	2208	2652	3090
FLOW	(gpm ↓)	Torque (in•lbf) Speed Specification						
	2.64	1558	3248	4956	6328	7833	9293	10701
		24 rpm	23 rpm	22 rpm	21 rpm	20 rpm	19 rpm	18 rpm
	5.28	1584	3275	5001	6426	7957	9479	10940
		49 rpm	48 rpm	47 rpm	44 rpm	42 rpm	40 rpm	38 rpm
	10.57	1558	3275	5018	6488	8134	9656	11178
		96 rpm	95 rpm	93 rpm	90 rpm	87 rpm	83 rpm	79 rpm
	15.85	1540	3195	4983	6452	8143	9692	11232
		145 rpm	143 rpm	139 rpm	135 rpm	131 rpm	127 rpm	121 rpm
	21.13	1469	3124	4894	6364	8072	9594	11178
193 rpm		191 rpm	188 rpm	184 rpm	180 rpm	1761 rpm	170 rpm	
26.42	1328	3000	4762	6266	7930	9444	11081	
	242 rpm	240 rpm	238 rpm	234 rpm	228 rpm	224 rpm	218 rpm	
33.02 Max Cont.	1195	2735	4638	6089	7727	9249	10807	
	302 rpm	300 rpm	298 rpm	294 rpm	289 rpm	285 rpm	178 rpm	
39.63 Max Int.	1115	2584	4496	5895	7541	9028	10594	
	364 rpm	362 rpm	358 rpm	354 rpm	350 rpm	346 rpm	339 rpm	

BMT 500		31.95 in³/rev (523.6 cm³/rev)					<i>Max Cont.</i>	<i>Max Int.</i>
Pressure (psi →)		440	880	1325	1766	2060	2355	2652
FLOW	(gpm ↓)	Torque (in·lbf) Speed Specification						
	2.64	1965	3992	6125	7895	9293	10559	11860
		18 rpm	18 rpm	18 rpm	17 rpm	16 rpm	15 rpm	13 rpm
	5.28	2045	4107	6319	8125	9470	10798	12187
		37 rpm	36 rpm	35 rpm	34 rpm	33 rpm	32 rpm	30 rpm
	10.57	2036	4124	6434	8329	9683	11010	12586
		75 rpm	74 rpm	73 rpm	72 rpm	70 rpm	68 rpm	64 rpm
	15.85	1991	4045	6319	8329	9630	11019	12471
		113 rpm	112 rpm	111 rpm	109 rpm	107 rpm	105 rpm	101 rpm
	21.13	1885	3815	6160	8205	9523	11010	12400
		151 rpm	150 rpm	149 rpm	147 rpm	145 rpm	143 rpm	138 rpm
	26.42	1717	3717	6019	7978	9408	10833	12241
		189 rpm	188 rpm	187 rpm	185 rpm	183 rpm	181 rpm	177 rpm
33.02 <i>Max Cont.</i>	1611	3523	5673	7762	9063	10612	11966	
	237 rpm	236 rpm	235 rpm	233 rpm	231 rpm	229 rpm	225 rpm	
39.63 <i>Max Int.</i>	1301	3266	5470	7550	8886	10239	11727	
	284 rpm	283 rpm	282 rpm	280 rpm	278 rpm	276 rpm	272 rpm	

BMT 630		38.39 in³/rev (629.1 cm³/rev)					<i>Max Cont.</i>	<i>Max Int.</i>
Pressure (psi →)		440	880	1325	1546	1766	2060	2355
FLOW	(gpm ↓)	Torque (in·lbf) Speed Specification						
	2.64	2062	4602	7036	7983	9505	10567	12063
		14 rpm	14 rpm	13 rpm	13 rpm	13 rpm	11 rpm	11 rpm
	5.28	2097	4903	7407	8434	9885	10965	12452
		28 rpm	27 rpm	27 rpm	26 rpm	26 rpm	24 rpm	22 rpm
	10.57	2115	4894	7611	8735	10364	11576	13125
		62 rpm	62 rpm	61 rpm	60 rpm	59 rpm	56 rpm	54 rpm
	15.85	1974	4814	7638	8655	10372	11664	13257
		94 rpm	94 rpm	92 rpm	91 rpm	90 rpm	86 rpm	82 rpm
	21.13	1947	5071	7558	8540	10372	11629	13248
		123 rpm	123 rpm	121 rpm	119 rpm	118 rpm	114 rpm	110 rpm
	26.42	1841	4620	7363	8363	10231	10231	13169
		156 rpm	155 rpm	153 rpm	152 rpm	150 rpm	147 rpm	142 rpm
33.02 <i>Max Cont.</i>	1779	4416	7169	8239	10062	11435	13028	
	196 rpm	196 rpm	194 rpm	192 rpm	191 rpm	187 rpm	183 rpm	
39.63 <i>Max Int.</i>	1540	4354	6947	8151	9912	11301	12868	
	233 rpm	232 rpm	231 rpm	230 rpm	227 rpm	223 rpm	217 rpm	

BMT 800		48.93 in³/rev (801.8 cm³/rev)					<i>Max Cont.</i>	<i>Max Int.</i>
Pressure (psi →)		440	880	1325	1546	1840	1914	
FLOW	(gpm ↓)	Torque (in·lbf) Speed Specification						
	2.64	3062	5991	8877	10257	12080	12302	
		12 rpm	12 rpm	11 rpm	11 rpm	11 rpm	10 rpm	
	5.28	3151	6124	9151	10470	12425	12903	
		24 rpm	24 rpm	24 rpm	23 rpm	22 rpm	18 rpm	
	10.57	3220	6222	9434	10939	12912	13417	
		50 rpm	50 rpm	49 rpm	48 rpm	46 rpm	40 rpm	
	15.85	3133	6222	9381	10947	12956	13417	
		74 rpm	73 rpm	71 rpm	71 rpm	68 rpm	63 rpm	
	21.13	2938	6071	9293	10850	12956	13399	
		99 rpm	98 rpm	98 rpm	96 rpm	93 rpm	86 rpm	
	26.42	3699	5788	9071	10682	12788	13328	
		125 rpm	123 rpm	123 rpm	121 rpm	118 rpm	110 rpm	
33.02 <i>Max Cont.</i>	2478	5505	8753	10452	12585	13160		
	154 rpm	153 rpm	153 rpm	150 rpm	149 rpm	140 rpm		
39.63 <i>Max Int.</i>	2186	5222	8454	10231	12443	13663		
	185 rpm	184 rpm	183 rpm	181 rpm	179 rpm	172 rpm		

BMT Technical Data

Shaft Seal Rated Pressure

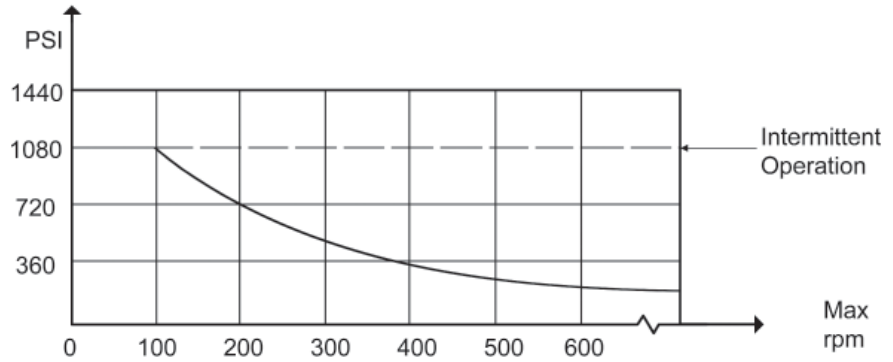
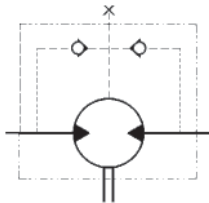

Case Drain

In applications without a motor drain line, the pressure exerted on the shaft seal is marginally in excess of the return line pressure. When the drain line is used, the pressure exerted on the shaft seal is equal to the return line pressure.

Shaft Rotation Direction

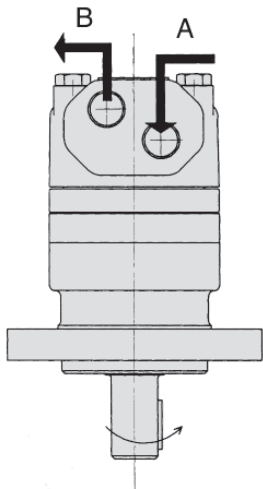

Axial and Radial forces

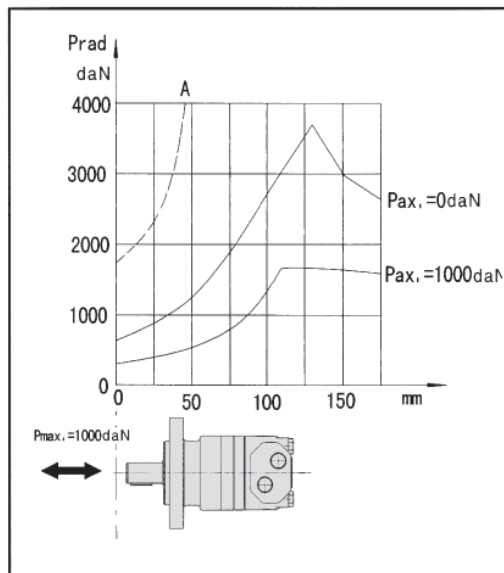

The output shaft runs tapered bearings that permit high axial and radial forces, Curve "A" shows max radial shaft load, Any shaft loads exceeding the values quoted in the curve will involve risk of breakage. The two other curves apply to a B10 bearing life of 3000 hours at 200 rpm.



FLUID COMPONENTS, INC.

Hydraulic Motor Model BMV

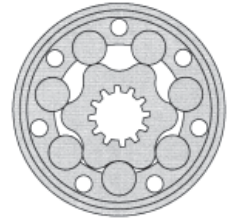
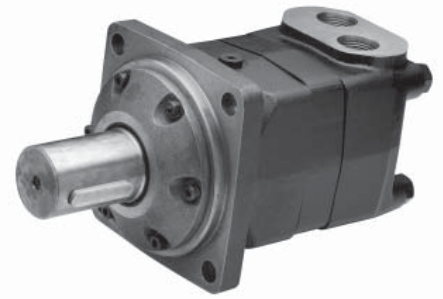

The BMV series motor adapts the advanced **ROLORTORC™** gear set design with **DISC** distribution flow and high pressure. These motors can be supplied with various options for multifunctional operations in accordance with the application requirements. The output shaft tapered roller bearings permit high axial and radial forces offering a smooth operation during low pressure start up and high pressure operation.

These low weight advanced construction design motors are manufactured in accordance with the requirements of the ISO 9000-2000 quality system.

Technical Specifications

MODEL		BMV 315	BMV 400	BMV 500	BMV 630	BMV 800	BMV 1000
Displacement	<i>in³/rev (cm³/rev)</i>	20.32 (333)	25.56 (419)	31.61 (518)	40.64 (666)	48.93 (802)	60.41 (990)
Max Speed	Cont	510	500	400	320	250	200
	Int.	630	600	480	380	300	240
Max Torque	Cont	8142	10443	12922	14692	16639	17834
	Int.	9736	12479	15577	17170	18675	20179
Max Differential	Cont	2900	2900	2900	2610	2320	2030
	Int.	3481	3481	3481	3045	2610	2320
Max Flow	Cont	42.3	52.8	52.8	52.8	52.8	52.8
	Int.	52.8	63.2	63.2	63.2	63.2	63.2
Weight		70 lbs	72 lbs	74 lbs	77 lbs	81 lbs	85 lbs

Continuous = maximum of continuous operation. Intermittent = maximum operating range for 6 seconds per minute

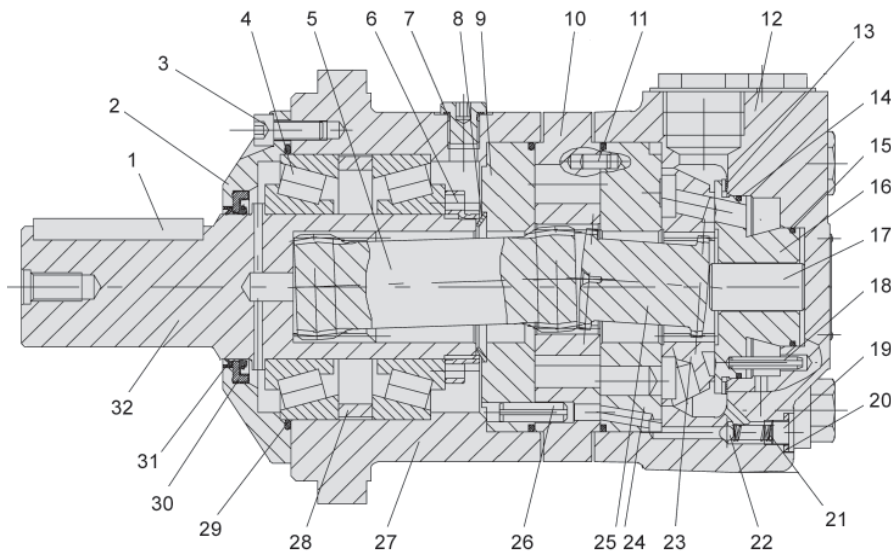
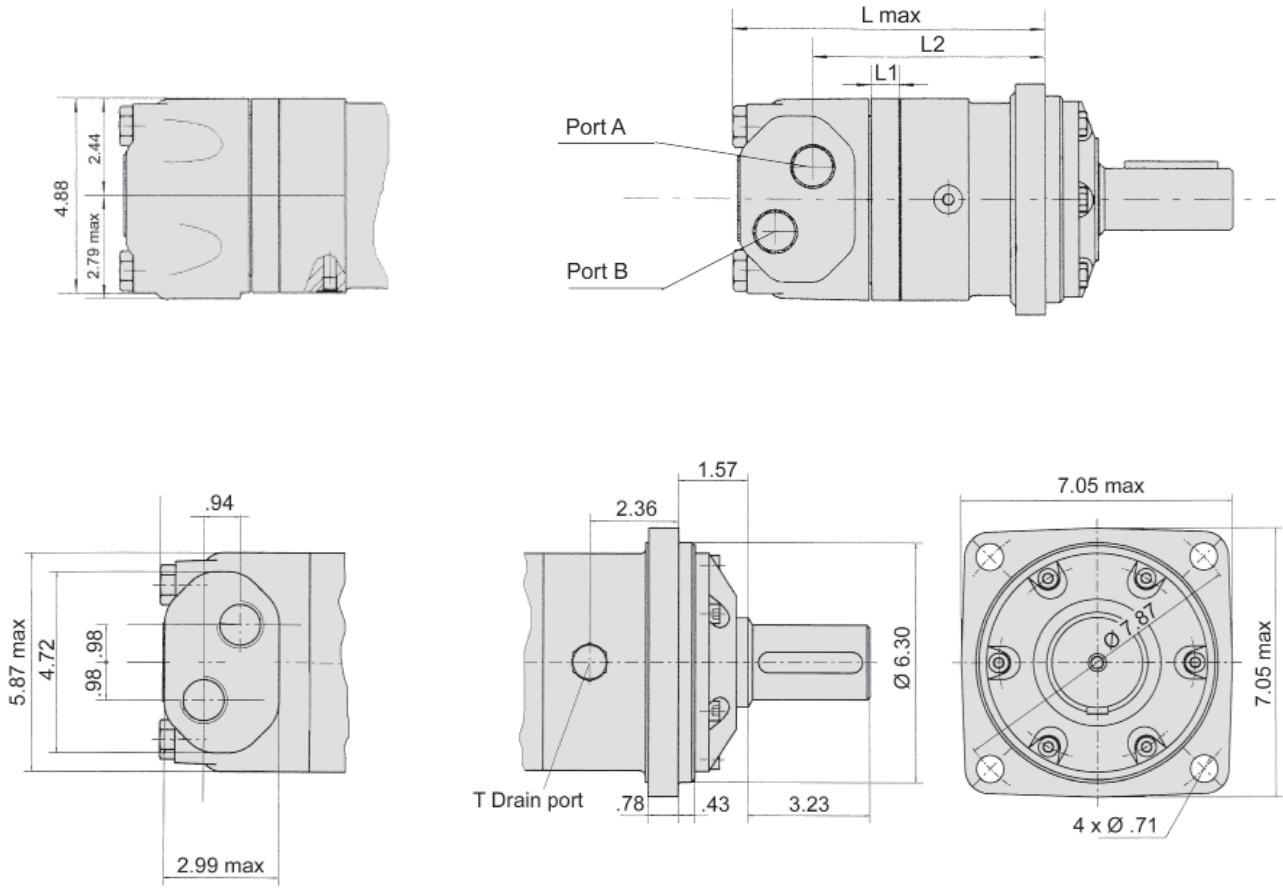

Diagram Key

- | | |
|---------------------------------|-------------------|
| 1 Parallel Key | 16 Balance Plate |
| 2 Flange | 17 Spacer |
| 3 Screw | 18 Pin |
| 4 Radial Tapered Roller Bearing | 19 Screw |
| 5 Drive | 20 Washer |
| 6 Lock Nut | 21 Spring |
| 7 Case Drain | 22 Ball |
| 8 Seal | 23 Valve Plate |
| 9 Intermediate Plate | 24 Channel Plate |
| 10 Rolortorc Set | 25 Valve Drive |
| 11 Pin | 26 Pin |
| 12 End Cover | 27 Housing |
| 13 Spring Washer | 28 Spacer Bushing |
| 14 "O" Ring | 29 "O" Ring |
| 15 "O" Ring | 30 Shaft Seal |
| | 31 Dust Seal |
| | 32 Shaft |

BMV Installation Data



MODEL	L	L1	L2
BMV 315	8.54"	0.79"	6.36"
BMV 400	8.82"	1.06"	6.63"
BMV 500	9.13"	1.38"	6.95"
BMV 630	9.60"	1.85"	7.42"
BMV 800	10.04"	2.28"	7.85"
BMV 1000	10.67"	2.91"	8.48"

Port	Port Size
P (A, B)	1 5/16-12 UNF
T	9/16-18 UNF

BMV Drive Shaft Data

B - 2 1/8" 16 DP Spline

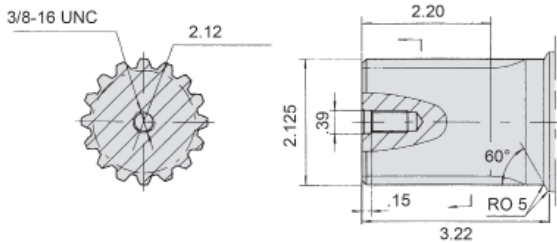

C - 2 1/4" Parallel Key

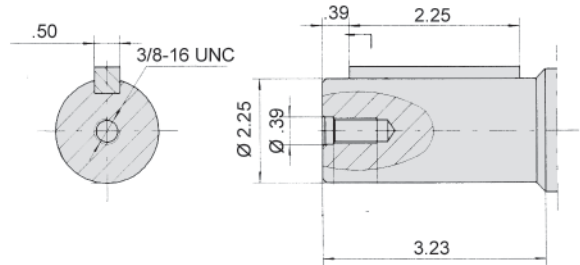

T1 - 2 1/4" Tapered

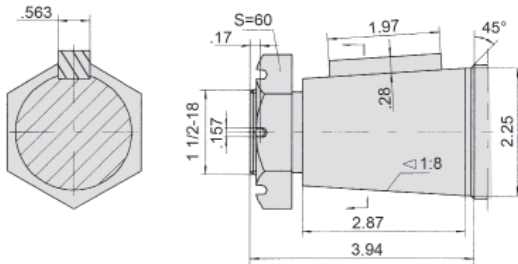

Ordering Example: **BMV** - **400** - **4** - **B** - **S1** -

Model	Frame Size	Mounting Flange**	Drive Shaft	Port Size	Options
BMV	315 (20.32) 400 (25.56) 500 (31.61) 630 (40.64) 800 (48.93) 1000 (60.41)	4 = 4-Bolt	B = 2 1/8" 16 DP Spline C = 2 1/4" Parallel Key T1 = 2 1/4" Tapered	S1 = 1 5/16-12 UNF	F* = Free Running

*Special Order

**Additional flange options available. Please consult factory.

Seal kits for BMV Motors are available for purchase. Order seal kit using item description: "BMV Seal Kit".

BMV Flow Data

BMV 315		20.32 in ³ /rev (333 cm ³ /rev)					Max Cont.	Max Int.
Pressure (psi →)		507	1015	1450	2030	2610	2900	3480
F L O W	(gpm ↓)	Torque (in•lbf) Speed Specification						
	2.64	1239	2602	3894	5398	6467	7478	8850
		26 rpm	24 rpm	23 rpm	22 rpm	20 rpm	17 rpm	14 rpm
	5.28	1354	2779	4124	5629	6965	7921	9470
		55 rpm	54 rpm	53 rpm	52 rpm	51 rpm	48 rpm	44 rpm
	13.21	1318	2761	4115	5788	7213	8275	9842
		145 rpm	144 rpm	142 rpm	140 rpm	137 rpm	133 rpm	127 rpm
	19.81	1265	2690	4058	5682	7222	8319	9903
		220 rpm	218 rpm	215 rpm	211 rpm	207 rpm	202 rpm	195 rpm
	26.42	1203	2628	4000	5629	7169	8284	9806
		294 rpm	292 rpm	290 rpm	287 rpm	283 rpm	278 rpm	270 rpm
	33.02	1088	2531	3912	5540	7071	8151	9673
		368 rpm	366 rpm	364 rpm	361 rpm	357 rpm	352 rpm	345 rpm
	39.63 Max Cont.	1008	2433	3850	5443	6974	8018	9541
445 rpm		443 rpm	441 rpm	437 rpm	430 rpm	422 rpm	410 rpm	
42.27	947	2371	3805	5381	6903	7921	9470	
	475 rpm	473 rpm	470 rpm	466 rpm	460 rpm	452 rpm	439 rpm	
52.83 Max Int.	725	2203	3646	5248	6708	7708	9266	
	596 rpm	594 rpm	590 rpm	584 rpm	576 rpm	565 rpm	544 rpm	

BMV 400		25.56 in ³ /rev (419 cm ³ /rev)					Max Cont.	Max Int.
Pressure (psi →)		507	1015	1450	2030	2610	2900	3480
F L O W	(gpm ↓)	Torque (in•lbf) Speed Specification						
	2.64	1619	3407	5027	6868	8567	9744	11435
		20 rpm	20 rpm	19 rpm	18 rpm	17 rpm	16 rpm	14 rpm
	5.28	1734	3522	5221	7213	8939	10196	11913
		44 rpm	44 rpm	43 rpm	42 rpm	40 rpm	39 rpm	37 rpm
	13.21	1770	3557	5336	7452	9204	10496	12656
		114 rpm	113 rpm	113 rpm	112 rpm	110 rpm	108 rpm	103 rpm
	19.81	1725	3487	5275	7416	9231	10514	12674
		175 rpm	173 rpm	170 rpm	166 rpm	163 rpm	1579 rpm	152 rpm
	26.42	1522	3407	5248	7319	9169	10479	12612
		236 rpm	235 rpm	233 rpm	231 rpm	227 rpm	223 rpm	215 rpm
	33.02	1478	3310	5159	7222	9036	10417	12506
		296 rpm	294 rpm	291 rpm	288 rpm	282 rpm	275 rpm	268 rpm
	39.63	1398	3195	4947	7089	8921	10311	12302
355 rpm		354 rpm	352 rpm	349 rpm	344 rpm	335 rpm	324 rpm	
46.23	1265	3062	4894	6938	8753	10134	12187	
	416 rpm	414 rpm	411 rpm	407 rpm	403 rpm	396 rpm	388 rpm	
52.83 Max Cont.	1044	2929	4743	6815	8576	9983	12001	
	475 rpm	473 rpm	469 rpm	463 rpm	455 rpm	448 rpm	439 rpm	
63.40 Max Int.	725	2664	4478	6549	8346	9771	11789	
	571 rpm	569 rpm	565 rpm	548 rpm	539 rpm	530 rpm	520 rpm	

BMV 500		31.61 in³/rev (518 cm³/rev)					<i>Max Cont.</i>	<i>Max Int.</i>	
Pressure (psi →)	507	1015	1450	2030	2610	2900	3480		
F L O W	(gpm ↓)	Torque (in•lbf) Speed Specification							
	2.64	2141	4142	6160	8487	10532	11975	14223	
		17 rpm	17 rpm	16 rpm	16 rpm	15 rpm	13 rpm	11 rpm	
	5.28	2169	4434	6531	8877	10904	12337	14674	
		36 rpm	35 rpm	35 rpm	34 rpm	33 rpm	32 rpm	29 rpm	
	13.21	2124	4425	6708	9072	11240	12824	15426	
		93 rpm	92 rpm	91 rpm	90 rpm	88 rpm	85 rpm	80 rpm	
	19.81	2062	4407	6655	9116	11399	13054	15630	
		140 rpm	139 rpm	137 rpm	135 rpm	132 rpm	127 rpm	120 rpm	
	26.42	2017	4345	6620	9080	11408	13028	15577	
		189 rpm	187 rpm	185 rpm	182 rpm	178 rpm	173 rpm	166 rpm	
	33.02	1947	4274	6567	8974	11328	12922	15444	
		237 rpm	236 rpm	234 rpm	231 rpm	227 rpm	223 rpm	216 rpm	
	39.63	1778	4115	6399	8921	11063	12647	15364	
287 rpm		286 rpm	284 rpm	281 rpm	276 rpm	270 rpm	260 rpm		
46.23	1610	3947	6292	8824	10957	12444	15179		
	335 rpm	334 rpm	332 rpm	329 rpm	325 rpm	320 rpm	310 rpm		
52.83 <i>Max Cont.</i>	1424	3743	6868	8620	10780	12258	15019		
	384 rpm	383 rpm	381 rpm	378 rpm	374 rpm	366 rpm	354 rpm		
63.40 <i>Max Int.</i>	1062	3345	6390	8151	10373	11859	14603		
	461 rpm	459 rpm	457 rpm	454 rpm	450 rpm	444 rpm	432 rpm		

BMV 630		40.64 in³/rev (666 cm³/rev)					<i>Max Cont.</i>	<i>Max Int.</i>	
Pressure (psi →)	507	870	1305	1740	2175	2610	3045		
F L O W	(gpm ↓)	Torque (in•lbf) Speed Specification							
	2.64	2478	4620	7186	9735	11222	13709	15789	
		14 rpm	13 rpm	13 rpm	12 rpm	12 rpm	11 rpm	10 rpm	
	5.28	2549	4885	7425	9744	11638	14223	16497	
		28 rpm	28 rpm	27 rpm	27 rpm	26 rpm	24 rpm	22 rpm	
	13.21	2557	4912	7682	10063	12072	14886	17312	
		72 rpm	72 rpm	71 rpm	69 rpm	68 rpm	66 rpm	62 rpm	
	19.81	2389	4850	7638	9912	11966	14869	17382	
		109 rpm	108 rpm	106 rpm	104 rpm	102 rpm	99 rpm	94 rpm	
	26.42	2336	4761	7576	9585	11948	14816	17391	
		146 rpm	145 rpm	143 rpm	141 rpm	138 rpm	135 rpm	130 rpm	
	33.02	2221	4566	7408	9479	11824	14683	17258	
		184 rpm	183 rpm	181 rpm	179 rpm	177 rpm	173 rpm	168 rpm	
	39.63	2124	4381	7231	9408	11771	14603	17064	
221 rpm		220 rpm	219 rpm	217 rpm	215 rpm	212 rpm	205 rpm		
46.23	1858	4292	7045	9310	11505	14479	16887		
	259 rpm	258 rpm	257 rpm	254 rpm	250 rpm	246 rpm	241 rpm		
52.83 <i>Max Cont.</i>	1610	4150	6646	9010	11328	14258	16665		
	297 rpm	297 rpm	295 rpm	293 rpm	290 rpm	284 rpm	273 rpm		
63.40 <i>Max Int.</i>	1150	3681	6301	8656	10948	13833	16241		
	358 rpm	357 rpm	355 rpm	351 rpm	346 rpm	340 rpm	332 rpm		

BMV 800		48.93 in ³ /rev (801 cm ³ /rev)					Max Cont.	Max Int.
Pressure (psi →)		262	725	1160	1450	1885	2320	2610
F L O W	(gpm ↓)	Torque (in•lbf) Speed Specification						
	2.64	2460	5000	7346	9691	12435	15152	16949
		11 rpm	10 rpm	10 rpm	9 rpm	8 rpm	8 rpm	7 rpm
	5.28	2495	5053	7478	10178	12886	15780	17648
		23 rpm	22 rpm	22 rpm	21 rpm	20 rpm	18 rpm	16 rpm
	13.21	2549	5151	7576	10284	12948	15842	17710
		60 rpm	59 rpm	57 rpm	56 rpm	54 rpm	52 rpm	48 rpm
	19.81	2380	5133	7567	10331	12966	15807	17639
		91 rpm	90 rpm	89 rpm	87 rpm	84 rpm	81 rpm	77 rpm
	26.42	2221	5009	7434	10089	12815	15639	17568
		122 rpm	121 rpm	120 rpm	118 rpm	115 rpm	111 rpm	105 rpm
	33.02	2141	4735	7293	9895	12630	15391	17489
		153 rpm	152 rpm	150 rpm	147 rpm	143 rpm	139 rpm	133 rpm
	39.63	2088	4655	7151	9753	12399	15170	17338
185 rpm		183 rpm	181 rpm	178 rpm	174 rpm	169 rpm	163 rpm	
46.23	1902	4460	7018	9549	12187	15028	17135	
	216 rpm	214 rpm	212 rpm	209 rpm	206 rpm	203 rpm	196 rpm	
52.83 Max Cont.	1743	4142	6770	9408	12054	14878	16931	
	247 rpm	245 rpm	243 rpm	240 rpm	237 rpm	232 rpm	225 rpm	
63.40 Max Int.	1044	3434	6310	9027	11665	14488	16267	
	297 rpm	296 rpm	295 rpm	293 rpm	288 rpm	283 rpm	277 rpm	

BMV 1000		60.41 in ³ /rev (990 cm ³ /rev)					Max Cont.	Max Int.
Pressure (psi →)		262	725	1015	1450	2030	2320	
F L O W	(gpm ↓)	Torque (in•lbf) Speed Specification						
	2.64	2761	5664	8594	12391	17506	19993	
		9 rpm	9 rpm	9 rpm	8 rpm	7 rpm	6 rpm	
	5.28	2832	5735	8656	12479	17524	20091	
		28 rpm	27 rpm	26 rpm	25 rpm	23 rpm	21 rpm	
	13.21	2885	5797	8779	12585	17834	20179	
		47 rpm	46 rpm	45 rpm	43 rpm	41 rpm	38 rpm	
	19.81	2814	5682	8735	12612	17728	20144	
		72 rpm	71 rpm	70 rpm	68 rpm	66 rpm	63 rpm	
	26.42	2734	5611	8700	12550	17648	19852	
		98 rpm	97 rpm	95 rpm	93 rpm	90 rpm	86 rpm	
	33.02	2726	5522	8629	12470	17595	19684	
		123 rpm	122 rpm	120 rpm	117 rpm	114 rpm	110 rpm	
	39.63	2460	5328	8505	12107	17374	19542	
149 rpm		148 rpm	146 rpm	144 rpm	140 rpm	133 rpm		
46.23	2336	5133	8372	11842	17037	19108		
	174 rpm	172 rpm	170 rpm	166 rpm	162 rpm	155 rpm		
52.83 Max Cont.	2035	4921	8071	11505	16789	18603		
	199 rpm	196 rpm	193 rpm	190 rpm	185 rpm	178 rpm		
63.40 Max Int.	1469	4540	7673	11470	16152	18002		
	240 rpm	237 rpm	233 rpm	229 rpm	225 rpm	218 rpm		

BMV Technical Data

Shaft Seal Rated Pressure

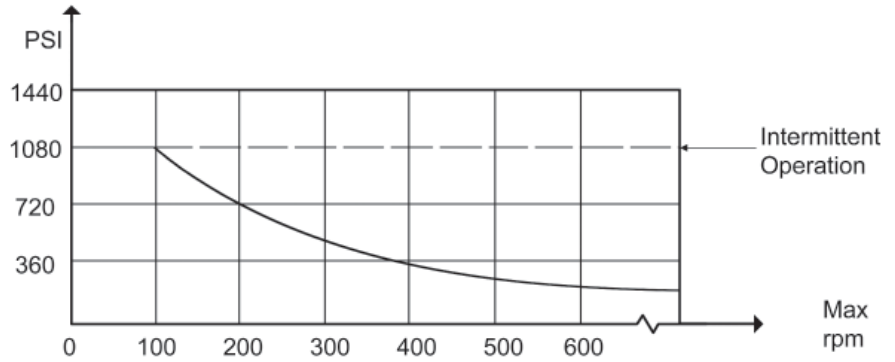
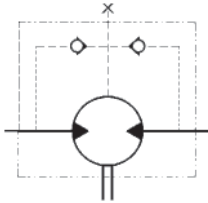

Shaft Rotation Direction

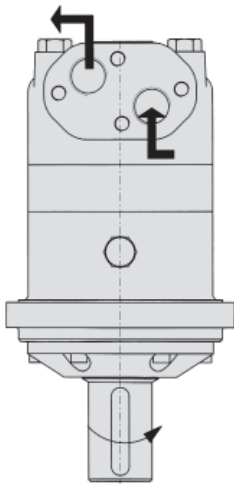

Axial and Radial forces

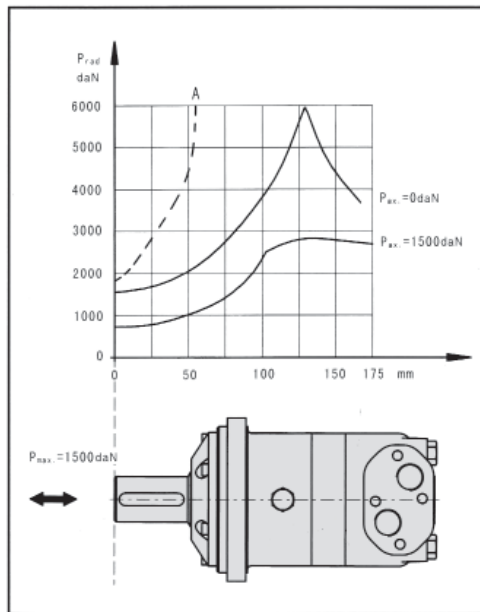

The output shaft runs tapered bearings that permit high axial and radial forces, Curve "A" shows max radial shaft load, Any shaft loads exceeding the values quoted in the curve will involve risk of breakage. The two other curves apply to a B10 bearing life of 3000 hours at 200 rpm.



FLUID COMPONENTS, INC.

Hydraulic Motor Model BMK6

Crossover to Char-Lynn® 6000 Series

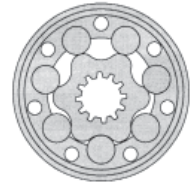

The BMK6 series motor adapts the advanced **ROLORTORC™** gear set design with **DISC** distribution flow and high pressure. These motors can be supplied with various options for multifunctional operations in accordance with the application requirements. The output shaft tapered roller bearings permit high axial and radial forces offering a smooth operation during low pressure start up and high pressure operation.

These low weight advanced construction design motors are manufactured in accordance with the requirements of the ISO 9000-2000 quality system.

Technical Specifications

MODEL		BMK6 200	BMK6 250	BMK6 315	BMK6 400	BMK6 500	BMK6 630	BMK6 800	BMK6 1000
Displacement <i>in³/rev (cm³/rev)</i>		11.93 (195.6)	15.01 (246.1)	19.01 (311.6)	23.87 (391.3)	29.95 (490.8)	38.01 (623)	48.96 (802.4)	59.90 (981.6)
Max Speed <i>rpm</i>	Cont	765	610	480	382	304	240	186	152
	Int.	865	830	690	570	455	360	280	230
Max Torque <i>in•lbf</i>	Cont	5000	6284	8142	10266	12789	13099	13984	14824
	Int.	7434	9558	11727	14382	16639	16726	16639	16462
Max Differential <i>psi</i>	Cont	2900	2900	2900	2900	2900	2538	2031	2031
	Int.	4351	4351	4351	4351	3988	3263	2538	2031
Max Flow <i>gpm</i>	Cont	39.62	39.62	39.62	39.62	39.62	39.62	39.62	39.62
	Int.	44.90	54.15	59.43	59.43	59.43	59.43	59.43	59.43
Weight		56 lbs	57 lbs	59 lbs	60 lbs	63 lbs	66 lbs	70 lbs	74 lbs

Continuous (Cont.) = maximum of continuous operation. Intermittent (Int.) = maximum operating range for 6 seconds per minute

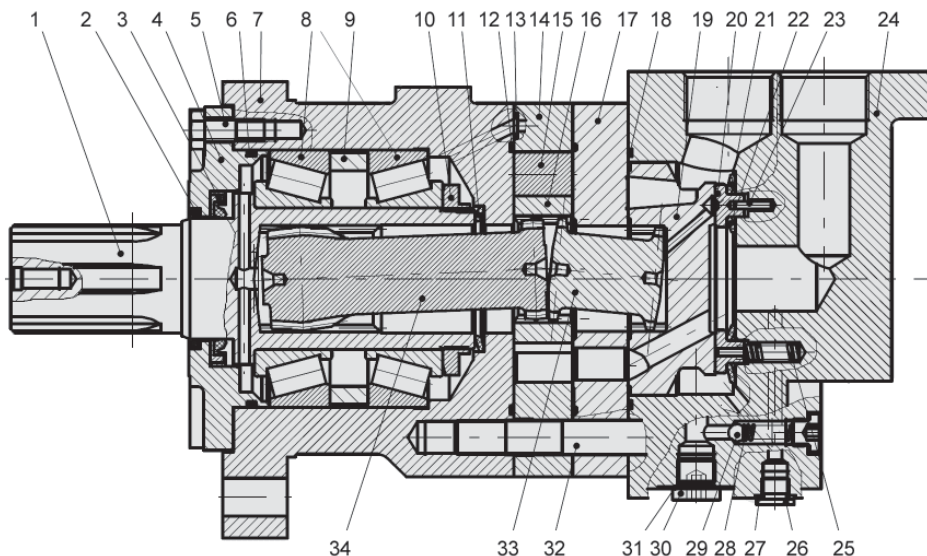

Diagram Key

- | | |
|---------------------|----------------------|
| 1 Output Shaft | 18 "O" Ring |
| 2 Dust Seal | 19 Distributor Plate |
| 3 Shaft Seal | 20 "O" Ring |
| 4 Front Cover | 21 Channel Plate |
| 5 Bolt | 22 Seal |
| 6 "O" Ring | 23 Seal |
| 7 Housing | 24 Pin |
| 8 Needle Bearing | 25 Spring |
| 9 Spacer Bushing | 26 Drain Plug |
| 10 Lock Nut | 27 "O" Ring |
| 11 Butterfly Washer | 28 Spring |
| 12 "O" Ring | 29 Ball |
| 13 Pin | 30 Drain Plug |
| 14 Stator | 31 Seal |
| 15 Roller | 32 Bolt |
| 16 Rotor | 33 Coupling |
| 17 Balance Plate | 34 Drive Link |

BMK6 Installation Data

CC - SAE "CC" Mount

Motor Size	L	L1	L2
200	10.43"	.85"	7.38"
250	10.67"	1.07"	7.60"
315	10.94"	1.36"	7.87"
400	11.30"	1.71"	8.23"
500	11.73"	2.14"	8.70"
630	12.32"	2.72"	9.25"
800	13.11"	3.50"	10.03"
1000	13.89"	4.29"	10.81"

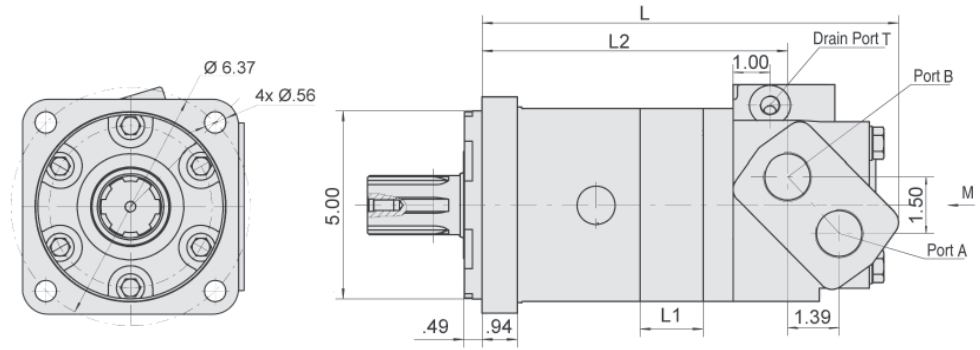

W - Wheel Mount

Motor Size	L	L1	L2
200	7.04"	0.85"	4.03"
250	7.28"	1.07"	4.25"
315	7.56"	1.36"	4.55"
400	7.91"	1.71"	4.90"
500	8.34"	2.14"	5.33"
630	8.92"	2.72"	5.91"
800	9.70"	3.50"	6.69"
1000	10.49"	4.29"	7.48"

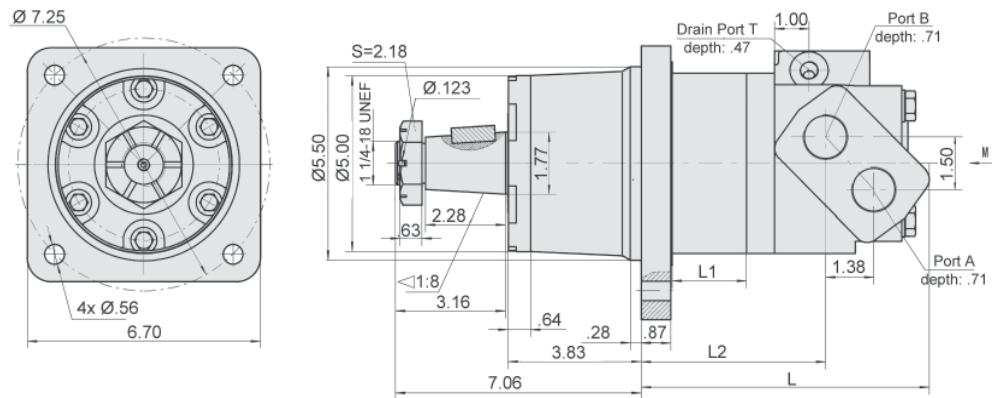

BMK6 Port Data

SF

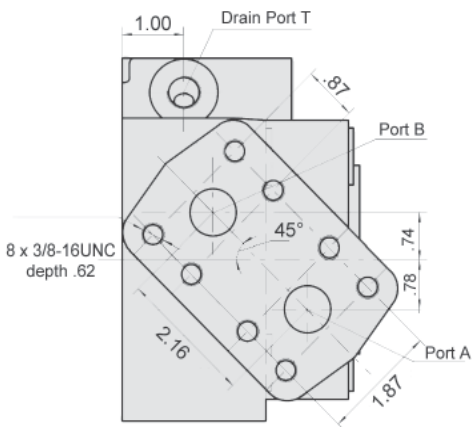

SF5 & SF7

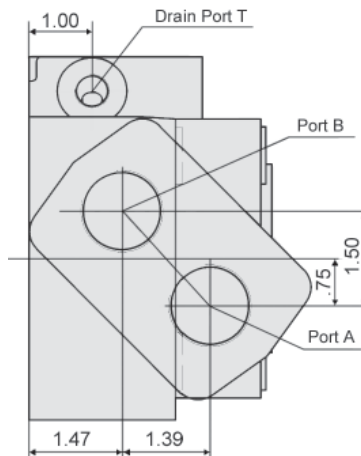

Port Sizes

Model	P (A, B)	T
SF	3/4" Split Flange	7/16-20 SAE
SF5	1 5/16-12 SAE	7/16-20 SAE
SF7	G1 (BSP)	G 1/4

BMK6 Drive Shaft Data

G2 - 1 1/2" Parallel Key

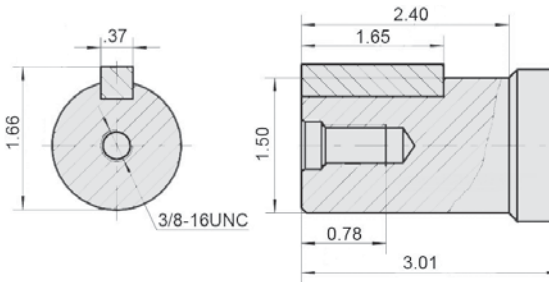

FE - 17-Tooth DP 12/24 Spline

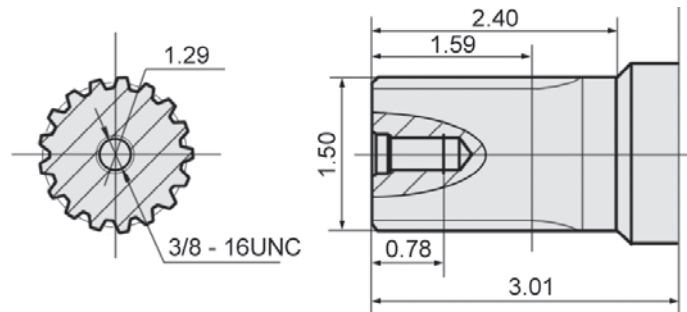

T1 - 1 3/4" Tapered

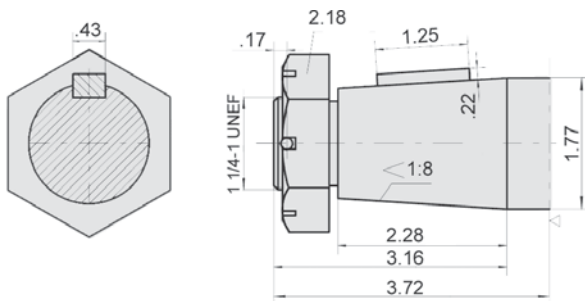

Y1 - 40 mm Parallel Key

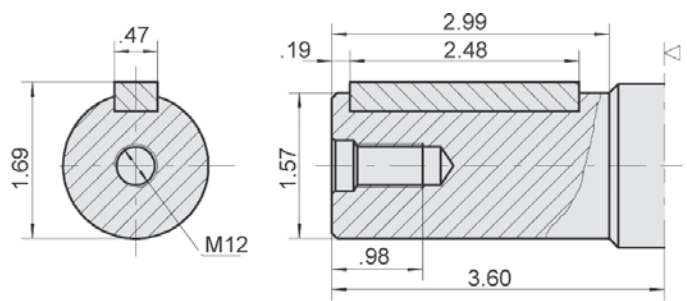

Ordering Example: Model **BMK6** - Frame Size **250** - Flange **CC** - Drive Shaft **G2** - Ports **SF5** - Rotation

Model	Frame Size	Mounting Flange	Drive Shaft**	Port Size	Rotation
BMK6	200 (11.93) 250 (15.01) 315 (19.01) 400 (23.87) 500 (29.95) 630 (38.01) 800 (48.96) 1000 (59.90)	CC = SAE "CC" W* = Wheel	G2 = 1 1/2" Parallel Key FE = 17-Tooth Spline T1* = 1 3/4" Tapered Y1* = 40mm Parallel Key	SF5 = 1 5/16-12 SAE SF* = 3/4" Split Flange SF7* = G1 (BSP) Staggered	Omit = Clockwise R = Counter-Clockwise <i>Note: Direction of rotation is indicated when "A" port is pressurized</i>

*Special Order
**Additional shaft options available. Please consult factory.

Seal kits for BMK6 motors are available for purchase. Order seal kit using item description: "BMK6 Seal Kit".

BMK6 200		11.93 in³/rev (195.6 cm³/rev)						<i>Max Cont.</i>	<i>Max Int.</i>	<i>Peak</i>	
Pressure (psi →)	254	508	1015	1523	2031	2538	2901	3481	3989	4351	
FLOW	(gpm ↓)	Torque (in·lbf) Speed Specification									
	0.52	265	646	1416							
		9 rpm	7 rpm	5 rpm							
	2.11	318	672	1486	2318	3053	3876	4115			
		39 rpm	38 rpm	35 rpm	34 rpm	31 rpm	27 rpm	16 rpm			
	3.96	318	716	1540	2389	3230	4027	4513	5133	5664	
		75 rpm	75 rpm	74 rpm	71 rpm	65 rpm	60 rpm	45 rpm	32 rpm	16 rpm	
	7.92	327	752	1548	2433	3274	4115	4779	5443	6195	6770
		152 rpm	151 rpm	147 rpm	142 rpm	132 rpm	121 rpm	109 rpm	96 rpm	80 rpm	60 rpm
	11.88	327	752	1593	2478	3319	4159	4735	5752	6549	7124
		228 rpm	227 rpm	223 rpm	218 rpm	210 rpm	200 rpm	185 rpm	165 rpm	146 rpm	110 rpm
	15.85	336	708	1575	2495	3365	4204	5000	5841	6638	7301
		305 rpm	304 rpm	302 rpm	297 rpm	288 rpm	280 rpm	255 rpm	235 rpm	210 rpm	170 rpm
	19.81	283	690	1548	2433	3345	4248	5000	5929	6726	7434
		382 rpm	380 rpm	376 rpm	370 rpm	362 rpm	350 rpm	328 rpm	300 rpm	270 rpm	230 rpm
	23.77	230	663	1522	2389	3319	4204	5000	5841	6770	
		459 rpm	456 rpm	452 rpm	445 rpm	436 rpm	420 rpm	405 rpm	383 rpm	355 rpm	
	27.73	194	619	1504	2389	3274	4159	4956	5841	6726	
536 rpm		534 rpm	530 rpm	523 rpm	510 rpm	496 rpm	470 rpm	435 rpm	400 rpm		
31.70	177	592	1469	2345	3230	4115	4956	5841	6682		
	612 rpm	610 rpm	605 rpm	598 rpm	585 rpm	570 rpm	536 rpm	502 rpm	485 rpm		
35.66	123	575	1416	2301	3186	4115	4956	5797	6638		
	690 rpm	687 rpm	680 rpm	672 rpm	650 rpm	638 rpm	595 rpm	550 rpm	485 rpm		
39.62 <i>Max Cont.</i>	88	531	1371	2285	3150	3982	4867	5752			
	765 rpm	765 rpm	755 rpm	740 rpm	725 rpm	700 rpm	640 rpm	580 rpm			
44.90 <i>Max Int.</i>		531	1371	2256	3097	3982	4825	5664			
		865 rpm	850 rpm	840 rpm	820 rpm	800 rpm	745 rpm	700 rpm			

BMK6 250		15.01 in³/rev (246.1 cm³/rev)						<i>Max Cont.</i>	<i>Max Int.</i>	<i>Peak</i>	
Pressure (psi →)	254	508	1015	1523	2031	2538	2901	3481	3989	4351	
FLOW	(gpm ↓)	Torque (in·lbf) Speed Specification									
	0.52	407	814								
		7 rpm	4 rpm								
	2.11	451	911	1902	2964	3894	4867	4956			
		31 rpm	30 rpm	27 rpm	24 rpm	21 rpm	15 rpm	10 rpm			
	3.96	460	929	1947	3009	4027	5044	5664	6593	7523	8496
		58 rpm	57 rpm	55 rpm	52 rpm	46 rpm	40 rpm	37 rpm	28 rpm	10 rpm	5 rpm
	7.92	486	973	2053	3115	4159	5310	6062	6992	7965	9027
		118 rpm	116 rpm	113 rpm	110 rpm	105 rpm	96 rpm	80 rpm	64 rpm	48 rpm	35 rpm
	11.88	513	973	2079	3142	4204	5398	6239	7434	8319	9293
		180 rpm	177 rpm	174 rpm	170 rpm	164 rpm	155 rpm	140 rpm	126 rpm	106 rpm	88 rpm
	15.85	469	973	2035	3097	4248	5443	6239	7478	8452	9558
		242 rpm	240 rpm	237 rpm	233 rpm	224 rpm	212 rpm	198 rpm	180 rpm	162 rpm	140 rpm
	19.81	398	929	2035	3142	4292	5487	6284	7525	8496	9558
		302 rpm	298 rpm	292 rpm	285 rpm	278 rpm	268 rpm	254 rpm	230 rpm	206 rpm	182 rpm
	23.77	398	929	1991	3097	4248	5443	6284	7478	8452	
		364 rpm	360 rpm	352 rpm	342 rpm	338 rpm	322 rpm	305 rpm	288 rpm	265 rpm	
	27.73	354	885	1947	3009	4204	5398	6239	7434	8408	
424 rpm		420 rpm	414 rpm	408 rpm	394 rpm	372 rpm	352 rpm	334 rpm	315 rpm		
31.70	336	840	1858	3009	4159	5221	6195	7346	8319		
	485 rpm	479 rpm	471 rpm	463 rpm	454 rpm	442 rpm	420 rpm	385 rpm	365 rpm		
35.66	309	752	1814	2876	4071	5133	6107	7257			
	546 rpm	540 rpm	532 rpm	525 rpm	516 rpm	504 rpm	478 rpm	445 rpm			
39.62 <i>Max Cont.</i>	265	708	1770	2832	3982	5044	6018	7213			
	608 rpm	605 rpm	600 rpm	592 rpm	580 rpm	566 rpm	532 rpm	496 rpm			
44.90		575	1681	2787	3894	4956	5974	6638			
		686 rpm	678 rpm	665 rpm	652 rpm	635 rpm	600 rpm	565 rpm			
48.87		1631	2743	3805	4823	5929					
		750 rpm	746 rpm	730 rpm	708 rpm	658 rpm					
54.15 <i>Max Int.</i>		1548	2655	3699	4743	4974					
		830 rpm	820 rpm	800 rpm	776 rpm	735 rpm					

BMK6 315											19.02 in ³ /rev (311.6 cm ³ /rev)					Max Cont.		Max Int.		Peak	
Pressure (psi →)		254	508	1015	1523	2031	2538	2901	3481	3989	4351										
F L O W	(gpm ↓)	Torque (in·lbf) Speed Specification																			
	0.52	575	1115																		
		5 rpm	4 rpm																		
	2.11	601	1144	2478	3628	4774	5752	6638	7788												
		24 rpm	23 rpm	22 rpm	20 rpm	16 rpm	13 rpm	9 rpm	3 rpm												
	3.96	619	1194	2522	3850	5000	6107	7169	8319	8939	9160										
		46 rpm	45 rpm	44 rpm	41 rpm	36 rpm	30 rpm	22 rpm	16 rpm	9 rpm	3 rpm										
	7.92	619	1194	2610	3894	5310	6549	7788	8762	9735	10443										
		93 rpm	92 rpm	90 rpm	86 rpm	80 rpm	71 rpm	62 rpm	52 rpm	43 rpm	31 rpm										
	11.88	619	1239	2655	4071	5398	6638	7965	9160	110311	11505										
		142 rpm	140 rpm	138 rpm	132 rpm	127 rpm	120 rpm	118 rpm	96 rpm	85 rpm	72 rpm										
	15.85	619	1239	2653	4071	5443	6859	8142	9337	10620	11727										
		190 rpm	189 rpm	186 rpm	182 rpm	176 rpm	167 rpm	154 rpm	138 rpm	124 rpm	105 rpm										
	19.81	575	1194	2610	4027	5443	6903	8742	9426	10735											
		238 rpm	237 rpm	235 rpm	231 rpm	225 rpm	214 rpm	200 rpm	180 rpm	160 rpm											
	23.77	531	1150	2566	3982	5443	6903	8142	9470	10797											
		285 rpm	284 rpm	280 rpm	276 rpm	270 rpm	260 rpm	245 rpm	226 rpm	210 rpm											
	27.73	442	1106	2478	3938	5354	6815	8098	9470	10665											
		335 rpm	333 rpm	330 rpm	324 rpm	316 rpm	302 rpm	290 rpm	271 rpm	248 rpm											
31.70	398	1062	2478	3894	5310	6770	8054	9331													
	384 rpm	382 rpm	380 rpm	372 rpm	364 rpm	350 rpm	338 rpm	312 rpm													
35.66	354	1017	2433	3850	5177	6726	7965	9293													
	432 rpm	428 rpm	420 rpm	412 rpm	408 rpm	391 rpm	380 rpm	350 rpm													
39.62 Max Cont.	309	973	2384	3717	5044	6682	7788	9116													
	480 rpm	475 rpm	462 rpm	458 rpm	450 rpm	435 rpm	420 rpm	395 rpm													
50.19		885	2168	3319	4602	6062	7257														
		595 rpm	580 rpm	574 rpm	560 rpm	548 rpm	530 rpm														
59.43 Max Int.			1947	3097	4225	5669	6815														
			690 rpm	683 rpm	674 rpm	652 rpm	634 rpm														

BMK6 400											23.87 in ³ /rev (391.3 cm ³ /rev)					Max Cont.		Max Int.		Peak	
Pressure (psi →)		254	508	1015	1523	2031	2538	2901	3481	3989	4351										
F L O W	(gpm ↓)	Torque (in·lbf) Speed Specification																			
	1.05	796	1522	3186																	
		4 rpm	2 rpm	1 rpm																	
	2.11	840	1593	3274	4912	6461	7832	9072	10576												
		19 rpm	18 rpm	17 rpm	16 rpm	14 rpm	12 rpm	9 rpm	4 rpm												
	3.96	840	1637	3319	4950	6549	8231	9470	11196	12214	14382										
		37 rpm	37 rpm	36 rpm	35 rpm	33 rpm	28 rpm	22 rpm	14 rpm	5 rpm	1 rpm										
	7.92	867	1637	3363	5089	6726	8496	10045	11683	12877	14382										
		75 rpm	74 rpm	73 rpm	71 rpm	68 rpm	65 rpm	55 rpm	45 rpm	31 rpm	20 rpm										
	11.88	840	1637	3407	5133	6770	8585	10134	11815	13541											
		114 rpm	113 rpm	111 rpm	108 rpm	105 rpm	100 rpm	90 rpm	80 rpm	72 rpm											
	15.85	796	1593	3363	5133	6815	8629	10222	11904												
		152 rpm	152 rpm	150 rpm	147 rpm	142 rpm	134 rpm	126 rpm	112 rpm												
	19.81	752	1593	3363	5133	6859	8673	10266	11992												
		191 rpm	191 rpm	188 rpm	186 rpm	181 rpm	172 rpm	160 rpm	148 rpm												
	23.77	708	1548	3319	5044	6770	8629	10222													
		230 rpm	229 rpm	227 rpm	224 rpm	220 rpm	212 rpm	200 rpm													
	27.73	619	1460	3186	4956	6726	8540	10178													
		268 rpm	267 rpm	265 rpm	260 rpm	254 rpm	246 rpm	232 rpm													
31.70	575	1416	3142	4867	6593	8408	10089														
	306 rpm	305 rpm	303 rpm	298 rpm	290 rpm	278 rpm	262 rpm														
35.66	486	1371	3009	4823	6505	8319	9912														
	345 rpm	343 rpm	337 rpm	330 rpm	322 rpm	310 rpm	295 rpm														
39.62 Max Cont.	398	1283	2832	4690	6461	8186															
	382 rpm	380 rpm	376 rpm	370 rpm	362 rpm	352 rpm															
50.19		1150	2655	4558	6461	8098															
		483 rpm	476 rpm	470 rpm	458 rpm	445 rpm															
59.43 Max Int.			2522	4425	6284	7921															
			570 rpm	560 rpm	550 rpm	535 rpm															

BMK6 500		29.95 in³/rev (490.8 cm³/rev)						<i>Max Cont.</i>	<i>Max Int.</i>	<i>Peak</i>
Pressure (psi →)	254	508	1015	1523	2031	2538	2901	3480	3988	
FLOW	(gpm ↓)	Torque (in•lbf) Speed Specification								
	1.05	1062	2035	4159	6062					
		7 rpm	6 rpm	5 rpm	3 rpm					
	2.11	1106	2124	4204	6239	8319	10311	12169		
		15 rpm	14 rpm	13 rpm	12 rpm	11 rpm	8 rpm	3 rpm		
	3.96	1106	2079	4248	6372	8496	10532	12391	14382	16639
		30 rpm	29 rpm	29 rpm	28 rpm	27 rpm	25 rpm	21 rpm	17 rpm	12 rpm
	7.92	1106	2079	4292	6505	8629	10753	12789	14913	
		60 rpm	59 rpm	58 rpm	57 rpm	54 rpm	50 rpm	45 rpm	35 rpm	
	11.88	1106	2079	4292	6505	8629	10753	12835		
		91 rpm	90 rpm	89 rpm	87 rpm	84 rpm	78 rpm	70 rpm		
	15.85	1062	2079	4248	6461	8629	10797	12922		
		121 rpm	121 rpm	120 rpm	118 rpm	114 rpm	108 rpm	98 rpm		
	19.81	973	1991	4159	6416	8585	10797			
		152 rpm	151 rpm	149 rpm	146 rpm	142 rpm	135 rpm			
	23.77	885	1947	4115	6372	8540	10753			
		182 rpm	182 rpm	180 rpm	178 rpm	175 rpm	168 rpm			
	27.73	840	1814	4071	6284	8496	10709			
213 rpm		212 rpm	210 rpm	206 rpm	201 rpm	195 rpm				
31.70	796	1725	3982	6195	8408	10665				
	244 rpm	243 rpm	240 rpm	235 rpm	228 rpm	221 rpm				
35.66	752	1548	3850	6018	8275	10355				
	274 rpm	273 rpm	270 rpm	265 rpm	258 rpm	250 rpm				
39.62 <i>Max Cont.</i>	619	1371	3717	5885	8142	10178				
	304 rpm	303 rpm	301 rpm	292 rpm	287 rpm	280 rpm				
50.19		1150	3186	5133	7655					
		385 rpm	382 rpm	373 rpm	365 rpm					
59.43 <i>Max Int.</i>			2832	4912	7080					
			455 rpm	440 rpm	432 rpm					

BMK6 630		38.01 in³/rev (623.0 cm³/rev)						<i>Max Cont.</i>	<i>Peak</i>
Pressure (psi →)	254	508	1015	1523	2031	2538	2901	3263	
FLOW	(gpm ↓)	Torque (in•lbf) Speed Specification							
	1.05	1150	2168	4425	6638				
		6 rpm	5 rpm	4 rpm	2 rpm				
	2.11	1194	2345	4779	7124	9243			
		12 rpm	12 rpm	11 rpm	10 rpm	8 rpm			
	3.96	1239	2478	5177	7655	9603	12612		
		24 rpm	23 rpm	22 rpm	21 rpm	16 rpm	13 rpm		
	7.92	1283	2610	5354	8186	11240	13099	15754	16727
		48 rpm	47 rpm	45 rpm	42 rpm	38 rpm	34 rpm	30 rpm	27 rpm
	11.88	1283	2610	5398	8142	11771	12966	15665	
		72 rpm	71 rpm	70 rpm	68 rpm	65 rpm	58 rpm	50 rpm	
	15.85	1194	2522	5354	8098	11771	12966		
		95 rpm	94 rpm	91 rpm	87 rpm	83 rpm	78 rpm		
	19.81	1150	2453	5266	8098	11722			
		120 rpm	119 rpm	116 rpm	112 rpm	106 rpm			
	23.77	1017	2301	5177	8009	11594			
		145 rpm	144 rpm	141 rpm	137 rpm	130 rpm			
	27.73	885	2256	5089	7921	11550			
168 rpm		167 rpm	164 rpm	160 rpm	152 rpm				
31.70	752	2079	4956	7788	11328				
	192 rpm	191 rpm	186 rpm	182 rpm	175 rpm				
35.66	663	1947	4779	7567					
	216 rpm	215 rpm	212 rpm	207 rpm					
39.62 <i>Max Cont.</i>	442	1770	4646	7434					
	240 rpm	239 rpm	236 rpm	233 rpm					
50.19			4115	7036					
			300 rpm	293 rpm					
59.43 <i>Max Int.</i>			3805	6549					
			360 rpm	348 rpm					

BMK6 800		48.96 in³/rev (802.4 cm³/rev)						<i>Max Cont.</i>	<i>Max Int.</i>	<i>Peak</i>	
Pressure (psi →)	254	508	725	1015	1233	1523	1740	2031	2248	2538	
FLOW	(gpm ↓)	Torque (in·lbf) Speed Specification									
	1.05	1522 4 rpm	3053 4 rpm	4690 2 rpm	6107 2 rpm	7611 1 rpm					
	2.11	1593 9 rpm	3142 9 rpm	4779 8 rpm	6416 8 rpm	8452 7 rpm	9558 6 rpm	11284 5 rpm	12037 4 rpm		
	3.96	1637 18 rpm	3274 18 rpm	5000 17 rpm	6708 17 rpm	8673 16 rpm	10001 15 rpm	11196 14 rpm	12568 12 rpm	14647 10 rpm	16639 9 rpm
	7.92	1681 36 rpm	3407 35 rpm	5221 34 rpm	7036 33 rpm	8894 32 rpm	10620 31 rpm	11771 29 rpm	13904 28 rpm	15400 26 rpm	
	11.88	1681 55 rpm	3407 55 rpm	5221 54 rpm	7880 53 rpm	8983 52 rpm	10620 52 rpm	12214 50 rpm	13718 48 rpm		
	15.85	1637 74 rpm	3363 73 rpm	5133 72 rpm	6992 70 rpm	8983 69 rpm	10620 67 rpm	11904 65 rpm			
	19.81	1557 92 rpm	3274 92 rpm	5089 91 rpm	6921 88 rpm	8850 87 rpm	10488 85 rpm	12081 82 rpm			
	23.77	1460 112 rpm	3186 111 rpm	4956 110 rpm	6770 108 rpm	8762 106 rpm	10355 102 rpm				
	27.73	1327 130 rpm	3009 129 rpm	4912 128 rpm	6638 127 rpm	8662 125 rpm	10222 120 rpm				
	31.70	1168 149 rpm	2816 148 rpm	4823 146 rpm	6505 143 rpm	8363 140 rpm	10001 135 rpm				
	35.66	929 168 rpm	2672 167 rpm	4646 165 rpm	6254 162 rpm	8063 158 rpm					
	39.62 <i>Max Cont.</i>	788 186 rpm	2389 185 rpm	4425 183 rpm	6018 180 rpm	7788 176 rpm					
	50.19		2655 235 rpm	4204 233 rpm	5841 230 rpm	7567 226 rpm					
	59.43 <i>Max Int.</i>			3743 280 rpm	5416 276 rpm	7346 272 rpm					

BMK6 1000		59.90 in³/rev (981.6 cm³/rev)						<i>Max Cont.</i>			
Pressure (psi →)	254	508	725	1015	1233	1523	1740	2031			
FLOW	(gpm ↓)	Torque (in·lbf) Speed Specification									
	1.05	1991 3 rpm	4071 3 rpm	5664 2 rpm	7744 2 rpm	9603 1 rpm					
	2.11	2035 7 rpm	4159 7 rpm	6151 6 rpm	8363 6 rpm	10355 5 rpm	12523 4 rpm	13807 3 rpm	14824 2 rpm		
	3.96	2124 15 rpm	4292 15 rpm	6328 15 rpm	8540 14 rpm	10620 14 rpm	12789 13 rpm	13984 13 rpm	15754 12 rpm		
	7.92	2124 30 rpm	4381 30 rpm	6372 30 rpm	8806 29 rpm	10930 28 rpm	13099 27 rpm	14515 25 rpm	16462 23 rpm		
	11.88	2124 45 rpm	4381 45 rpm	6372 44 rpm	8850 44 rpm	11063 43 rpm	13187 42 rpm	15046 40 rpm			
	15.85	2079 60 rpm	4336 60 rpm	6328 60 rpm	8762 59 rpm	11019 57 rpm	13276 55 rpm				
	19.81	1991 76 rpm	4204 76 rpm	6284 76 rpm	8673 75 rpm	10886 73 rpm	13143 70 rpm				
	23.77	1902 91 rpm	4071 91 rpm	6234 91 rpm	8496 90 rpm	10753 88 rpm	12966 85 rpm				
	27.73	1770 106 rpm	3938 106 rpm	6107 105 rpm	8319 105 rpm	10576 103 rpm	12745 100 rpm				
	31.70	1637 122 rpm	3717 122 rpm	5885 121 rpm	8142 119 rpm	10222 116 rpm					
	35.66	1327 137 rpm	3451 137 rpm	5620 136 rpm	7877 136 rpm	9912 134 rpm					
	39.62 <i>Max Cont.</i>	973 152 rpm	3186 151 rpm	5354 150 rpm	7611 148 rpm	9558 145 rpm					
	50.19		2832 192 rpm	5089 190 rpm	7257 188 rpm	9249 185 rpm					
	59.43 <i>Max Int.</i>			4558 230 rpm	7080 228 rpm	9027 224 rpm					

BMK6 Technical Data

Shaft Seal Rated Pressure

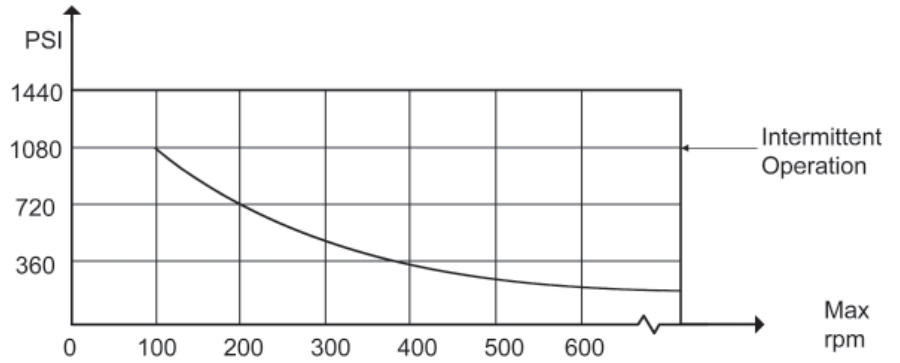
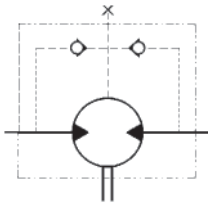

Case Drain

In applications without a motor drain line, the pressure exerted on the shaft seal is marginally in excess of the return line pressure. When the drain line is used the pressure exerted on the shaft seal is equal to the return line pressure.

Shaft Rotation Direction

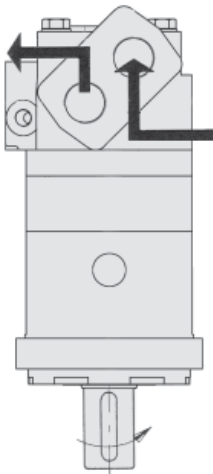

BMK6 for CC Mounting Radial forces

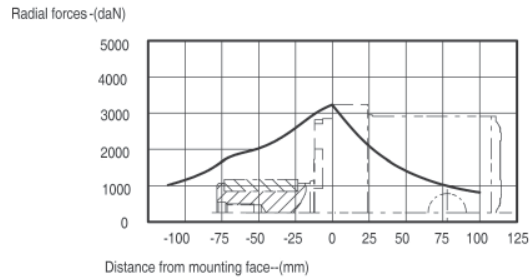

The bearing curve represents allowable bearing loads for an B10 bearing life (2000 hours or 12x10⁶ revolutions at 100rpm) at rated output torque. Other speed load multiply a load values.

The maximum load curve is defined by bearing static load capacity.

This curve should not be exceeded at any time including shock loads.



FLUID COMPONENTS, INC.

Hydraulic Gear Motor

Model GM-F10

Available by Special Order Only



The Model GM-F10 Gear Motor is constructed of an aluminum gear body and end plates and is available in 8 displacement sizes from 0.08 - 0.48 in³/rev. (1.3 - 8.0 cm³/rev). The standard mounting flange is a SAE AA - 2-bolt; standard ports are SAE-6 inlet and SAE-6 outlet; and the drive shaft is a 1/2" diameter straight shaft with 1/8" key.

Recommended working conditions:

FILTRATION: 25 micron or better
 OIL TEMP: -25° - 80° C (-12° - 175° F)

OIL VISCOSITY: 6 - 200 cSt
 AMBIENT -22° - 55° C (-8° - 130° F)

INLET PRESSURE: 12 - 32 psi absolute

Technical Specifications

Model	Displacement in ³ (cm ³) / rev	Pressure psi	Speed - rpm		Weight lbs	L	L1	Ports	
			Rated	Max				In	Out
GM-F10-13	0.08 (1.3)	3625	2000	5000	6.02	3.23"	1.65"	SAE-6	SAE-6
GM-F10-20	0.12 (2.0)	3625	2000	5000	6.31	3.30"	1.69"	SAE-6	SAE-6
GM-F10-27	0.16 (2.7)	3625	2000	5000	6.68	3.39"	1.73"	SAE-6	SAE-6
GM-F10-34	0.20 (3.4)	3625	2000	5000	6.99	3.46"	1.77"	SAE-6	SAE-6
GM-F10-41	0.25 (4.1)	3625	2000	4000	7.34	3.54"	1.81"	SAE-6	SAE-6
GM-F10-51	0.31 (5.1)	3625	2000	4000	7.78	3.66"	1.87"	SAE-6	SAE-6
GM-F10-61	0.37 (6.1)	3625	2000	4000	8.18	3.78"	1.93"	SAE-6	SAE-6
GM-F10-80	0.48 (8.0)	3480	2000	4000	9.01	3.97"	2.01"	SAE-6	SAE-6

Flow Rate (gpm) = Displacement (in³/rev) X Speed (rpm) / 231
 Volumetric efficiency % ≥93

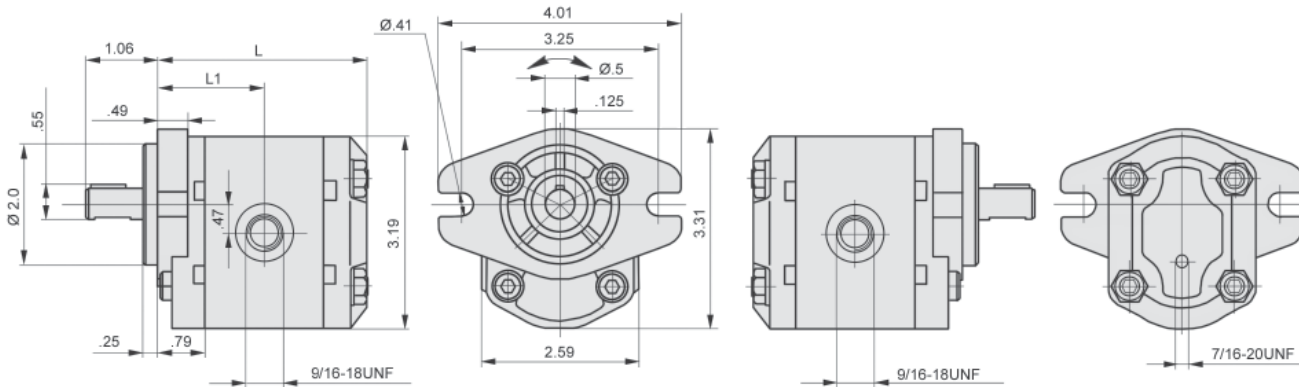

Ordering Example:



Category	Series	Frame Size	Drive Shaft	Rotation
GM = Gear Motor	F10 = F10 Series	13/20/27/34 41/51/61/80	P = 1/2" dia. Straight	C = Clockwise A = Counter-Clockwise B = Bidirectional* (viewed from shaft end)

*Special Order

GAUGES & ACCESSORIES

HYDRAULIC PUMPS

HYDRAULIC MOTORS

APPENDIX

DYNAMIC

FLUID COMPONENTS, INC.

Hydraulic Gear Motor

Model GM-F20

Available by Special Order Only

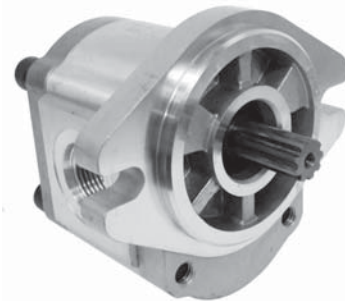

The GM-F20 Gear Motor is constructed of an aluminum gear body and end plates and is available in 11 displacement sizes from 0.24 - 1.52 in³/rev (4 - 25 cm³/rev). The standard mounting flange is SAE "A" 2-bolt. The standard drive shaft is a 5/8" diameter straight shaft with a 5/32" key - other shaft options available as outlined in Ordering Example.

Recommended working conditions:

FILTRATION: 25 micron or better
OIL TEMP: -25° - 80° C (-12° - 175° F)

OIL VISCOSITY: 6 - 200 cSt
AMBIENT -22° - 55° C (-8° - 130° F)

INLET PRESSURE: 12 - 32 psi absolute

Technical Specifications

Model	Displacement in ³ (cm ³) / rev	Pressure - psi		Speed - rpm			L	L1	Ports	
		Rated	Max	Rated	Max	Min			In	Out
GM-F20-04	0.24 (4)	2900	3625	2000	4000	500	3.70"	1.69"	SAE-12	SAE-12
GM-F20-06	0.36 (6)	2900	3625	2000	4000	500	3.87"	1.77"	SAE-12	SAE-12
GM-F20-08	0.48 (8)	2900	3625	2000	3500	500	3.95"	1.85"	SAE-12	SAE-12
GM-F20-10	0.61 (10)	2900	3625	2000	3500	500	4.12"	1.89"	SAE-12	SAE-12
GM-F20-12	0.73 (12)	2900	3625	2000	3500	500	4.25"	1.97"	SAE-12	SAE-12
GM-F20-14	0.85 (14)	2900	3625	2000	3500	500	4.35"	2.00"	SAE-12	SAE-12
GM-F20-16	0.97 (16)	2900	3625	2000	3000	500	4.50"	2.07"	SAE-12	SAE-12
GM-F20-18	1.09 (18)	2900	3625	2000	3000	500	4.60"	2.16"	SAE-12	SAE-12
GM-F20-20	1.22 (20)	2900	3625	2000	3000	500	4.72"	2.20"	SAE-12	SAE-12
GM-F20-23	1.40 (23)	2900	3625	2000	3000	500	4.84"	2.28"	SAE-12	SAE-12
GM-F20-25	1.52 (25)	2900	3625	2000	3000	500	5.05"	2.36"	SAE-16	SAE-16

Flow Rate (gpm) = Displacement (in³/rev) X speed (rpm) / 231
Volumetric efficiency % ≥93

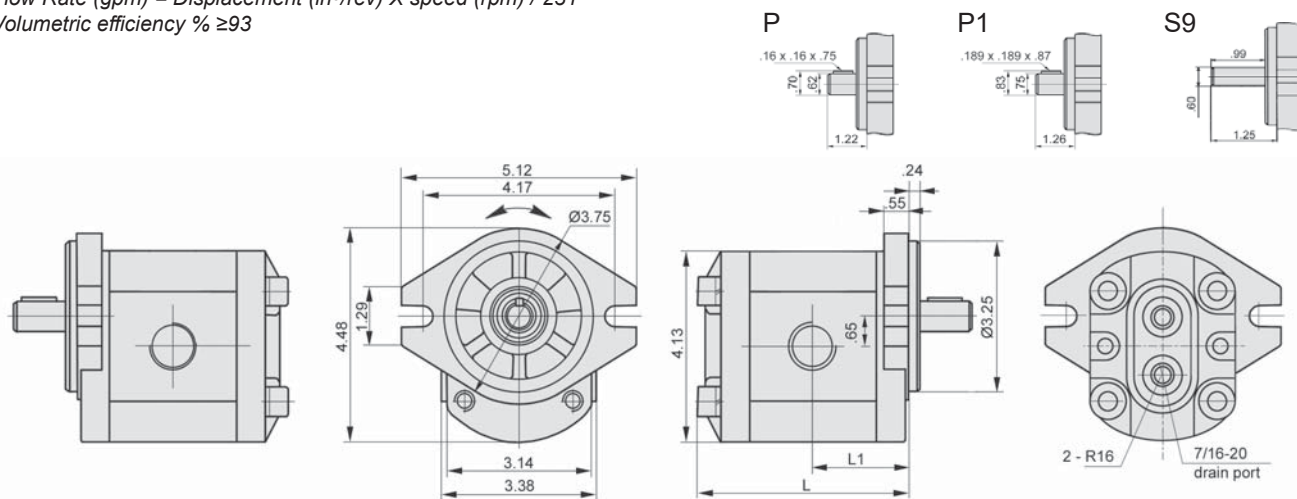
**Ordering Example:**

Category: **GM** - Series: **F20** - Displacement: **16** - Drive Shaft: **P** - Rotation: **A**

Category	Series	Frame Size	Drive Shaft	Rotation
GM = Gear Motor	F20 = F20 Series	04/06/08/10/12 14/16/18/20/23/25	P = 5/8" dia. Straight P1 = 3/4" dia. Straight S9 = SAE 9-tooth Spline	C = Clockwise A = Counter-Clockwise B = Bidirectional* (viewed from shaft end)

*Special Order